



Grade 5 B.E.S.T. Instructional Guide for Mathematics

The B.E.S.T. Instructional Guide for Mathematics (B1G-M) is intended to assist educators with planning for student learning and instruction aligned to Florida's Benchmarks for Excellent Student Thinking (B.E.S.T.) Standards. This guide is designed to aid high-quality instruction through the identification of components that support the learning and teaching of the B.E.S.T. Mathematics Standards and Benchmarks. The B1G-M includes an analysis of information related to the B.E.S.T. Standards for Mathematics within this specific mathematics course, the instructional emphasis and aligned resources. This document is posted on the [B.E.S.T. Standards for Mathematics webpage](#) of the Florida Department of Education's website and will continue to undergo edits as needed.

Structural Framework and Intentional Design of the B.E.S.T. Standards for Mathematics

Florida's B.E.S.T. Standards for Mathematics were built on the following.

- The coding scheme for the standards and benchmarks was changed to be consistent with other content areas. The new coding scheme is structured as follows: Content.GradeLevel.Strand.Standard.Benchmark.
- Strands were streamlined to be more consistent throughout.
- The standards and benchmarks were written to be clear and concise to ensure that they are easily understood by all stakeholders.
- The benchmarks were written to allow teachers to meet students' individual skills, knowledge and ability.
- The benchmarks were written to allow students the flexibility to solve problems using a method or strategy that is accurate, generalizable and efficient depending on the content (i.e., the numbers, expressions or equations).
- The benchmarks were written to allow for student discovery (i.e., exploring) of strategies rather than the teaching, naming and assessing of each strategy individually.
- The benchmarks were written to support multiple pathways for success in career and college for students.
- The benchmarks should not be taught in isolation but should be combined purposefully.
- The benchmarks may be addressed at multiple points throughout the year, with the intention of gaining mastery by the end of the year.
- Appropriate progression of content within and across strands was developed for each grade level and across grade levels.
- There is an intentional balance of conceptual understanding and procedural fluency with the application of accurate real-world context intertwined within mathematical concepts for relevance.
- The use of other content areas, like science and the arts, within real-world problems should be accurate, relevant, authentic and reflect grade-level appropriateness.

Components of the B.E.S.T. Instructional Guide for Mathematics

The following table is an example of the layout for each benchmark and includes the defining attributes for each component. It is important to note that instruction should not be limited to the possible connecting benchmarks, related terms, strategies or examples provided. To do so would strip the intention of an educator meeting students' individual skills, knowledge and abilities.

Benchmark

focal point for instruction within lesson or task

This section includes the benchmark as identified in the [B.E.S.T. Standards for Mathematics](#). The benchmark, also referred to as the Benchmark of Focus, is the focal point for student learning and instruction. The benchmark, and its related example(s) and clarification(s), can also be found in the course description. The 9-12 benchmarks may be included in multiple courses; select the example(s) or clarification(s) as appropriate for the identified course.

Connecting Benchmarks/Horizontal Alignment

in other standards within the grade level or course

This section includes a list of connecting benchmarks that relate horizontally to the Benchmark of Focus. Horizontal alignment is the intentional progression of content within a grade level or course linking skills within and across strands. Connecting benchmarks are benchmarks that either make a mathematical connection or include prerequisite skills. The information included in this section is not a comprehensive list, and educators are encouraged to find other connecting benchmarks. Additionally, this list will not include benchmarks from the same standard since benchmarks within the same standard already have an inherent connection.

Terms from the K-12 Glossary

This section includes terms from Appendix C: K-12 Glossary, found within the B.E.S.T. Standards for Mathematics document, which are relevant to the identified Benchmark of Focus. The terms included in this section should not be viewed as a comprehensive vocabulary list, but instead should be considered during instruction or act as a reference for educators.

Vertical Alignment

across grade levels or courses

This section includes a list of related benchmarks that connect vertically to the Benchmark of Focus. Vertical alignment is the intentional progression of content from one year to the next, spanning across multiple grade levels. Benchmarks listed in this section make mathematical connections from prior grade levels or courses in future grade levels or courses within and across strands. If the Benchmark of Focus is a new concept or skill, it may not have any previous benchmarks listed. Likewise, if the Benchmark of Focus is a mathematical skill or concept that is finalized in learning and does not have any direct connection to future grade levels or courses, it may not have any future benchmarks listed. The information included in this section is not a comprehensive list, and educators are encouraged to find other benchmarks within a vertical progression.

Purpose and Instructional Strategies

This section includes further narrative for instruction of the benchmark and vertical alignment. Additionally, this section may also include the following:

- explanations and details for the benchmark;
- vocabulary not provided within Appendix C;
- possible instructional strategies and teaching methods; and
- strategies to embed potentially related Mathematical Thinking and Reasoning Standards (MTRs).

Common Misconceptions or Errors

This section will include common student misconceptions or errors and may include strategies to address the identified misconception or error. Recognition of these misconceptions and errors enables educators to identify them in the classroom and make efforts to correct the misconception or error. This corrective effort in the classroom can also be a form of formative assessment within instruction.

Strategies to Support Tiered Instruction

The instructional strategies in this section address the common misconceptions and errors listed within the above section that can be a barrier to successfully learning the benchmark. All instruction and intervention at Tiers 2 and 3 are intended to support students to be successful with Tier 1 instruction. Strategies that support tiered instruction are intended to assist teachers in planning across any tier of support and should not be considered exclusive or inclusive of other instructional strategies that may support student learning with the B.E.S.T. Mathematics Standards. For more information about tiered instruction, please see the Effective Tiered Instruction for Mathematics: ALL Means ALL document.

Instructional Tasks

demonstrate the depth of the benchmark and the connection to the related benchmarks

This section will include example instructional tasks, which may be open-ended and are intended to demonstrate the depth of the benchmark. Some instructional tasks include integration of the Mathematical Thinking and Reasoning Standards (MTRs) and related benchmark(s). Enrichment tasks may be included to make connections to benchmarks in later grade levels or courses. Tasks may require extended time, additional materials and collaboration.

Instructional Items

demonstrate the focus of the benchmark

This section will include example instructional items which may be used as evidence to demonstrate the students' understanding of the benchmark. Items may highlight one or more parts of the benchmark.

**The strategies, tasks and items included in the BIG-M are examples and should not be considered comprehensive.*

Mathematical Thinking and Reasoning Standards

MTRs: Because Math Matters

Florida students are expected to engage with mathematics through the Mathematical Thinking and Reasoning Standards (MTRs) by utilizing their language as a self-monitoring tool in the classroom, promoting deeper learning and understanding of mathematics. The MTRs are standards which should be used as a lens when planning for student learning and instruction of the B.E.S.T. Standards for Mathematics.

Structural Framework and Intentional Design of the Mathematical Thinking and Reasoning Standards

The Mathematical Thinking and Reasoning Standards (MTRs) are built on the following.

- The MTRs have the same coding scheme as the standards and benchmarks; however, they are written at the standard level because there are no benchmarks.
- In order to fulfill Florida’s unique coding scheme, the 5th place (benchmark) will always be a “1” for the MTRs.
- The B.E.S.T. Standards for Mathematics should be taught through the lens of the MTRs.
- At least one of the MTRs should be authentically and appropriately embedded throughout every lesson based on the expectation of the benchmark(s).
- The bulleted language of the MTRs were written for students to use as self-monitoring tools during daily instruction.
- The clarifications of the MTRs were written for teachers to use as a guide to inform their instructional practices.
- The MTRs ensure that students stay engaged, persevere in tasks, share their thinking, balance conceptual understanding and procedures, assess their solutions, make connections to previous learning and extended knowledge, and apply mathematical concepts to real-world applications.
- The MTRs should not stand alone as a separate focus for instruction, but should be combined purposefully.
- The MTRs will be addressed at multiple points throughout the year, with the intention of gaining mastery of mathematical skills by the end of the year and building upon these skills as they continue in their K-12 education.

MA.K12.MTR.1.1 Actively participate in effortful learning both individually and collectively.

Mathematicians who participate in effortful learning both individually and with others:

- Analyze the problem in a way that makes sense given the task.
- Ask questions that will help with solving the task.
- Build perseverance by modifying methods as needed while solving a challenging task.
- Stay engaged and maintain a positive mindset when working to solve tasks.
- Help and support each other when attempting a new method or approach.

Clarifications:

Teachers who encourage students to participate actively in effortful learning both individually and with others:

- Cultivate a community of growth mindset learners.
- Foster perseverance in students by choosing tasks that are challenging.
- Develop students' ability to analyze and problem solve.
- Recognize students' effort when solving challenging problems.

MA.K12.MTR.2.1 Demonstrate understanding by representing problems in multiple ways.

Mathematicians who demonstrate understanding by representing problems in multiple ways:

- Build understanding through modeling and using manipulatives.
- Represent solutions to problems in multiple ways using objects, drawings, tables, graphs and equations.
- Progress from modeling problems with objects and drawings to using algorithms and equations.
- Express connections between concepts and representations.
- Choose a representation based on the given context or purpose.

Clarifications:

Teachers who encourage students to demonstrate understanding by representing problems in multiple ways:

- Help students make connections between concepts and representations.
- Provide opportunities for students to use manipulatives when investigating concepts.
- Guide students from concrete to pictorial to abstract representations as understanding progresses.
- Show students that various representations can have different purposes and can be useful in different situations.

MA.K12.MTR.3.1 Complete tasks with mathematical fluency.

Mathematicians who complete tasks with mathematical fluency:

- Select efficient and appropriate methods for solving problems within the given context.
- Maintain flexibility and accuracy while performing procedures and mental calculations.
- Complete tasks accurately and with confidence.
- Adapt procedures to apply them to a new context.
- Use feedback to improve efficiency when performing calculations.

Clarifications:

Teachers who encourage students to complete tasks with mathematical fluency:

- Provide students with the flexibility to solve problems by selecting a procedure that allows them to solve efficiently and accurately.
- Offer multiple opportunities for students to practice efficient and generalizable methods.
- Provide opportunities for students to reflect on the method they used and determine if a more efficient method could have been used.

MA.K12.MTR.4.1 Engage in discussions that reflect on the mathematical thinking of self and others.

Mathematicians who engage in discussions that reflect on the mathematical thinking of self and others:

- Communicate mathematical ideas, vocabulary and methods effectively.
- Analyze the mathematical thinking of others.
- Compare the efficiency of a method to those expressed by others.
- Recognize errors and suggest how to correctly solve the task.
- Justify results by explaining methods and processes.
- Construct possible arguments based on evidence.

Clarifications:

Teachers who encourage students to engage in discussions that reflect on the mathematical thinking of self and others:

- Establish a culture in which students ask questions of the teacher and their peers, and error is an opportunity for learning.
- Create opportunities for students to discuss their thinking with peers.
- Select, sequence and present student work to advance and deepen understanding of correct and increasingly efficient methods.
- Develop students' ability to justify methods and compare their responses to the responses of their peers.

MA.K12.MTR.5.1 Use patterns and structure to help understand and connect mathematical concepts.

Mathematicians who use patterns and structure to help understand and connect mathematical concepts:

- Focus on relevant details within a problem.
- Create plans and procedures to logically order events, steps or ideas to solve problems.
- Decompose a complex problem into manageable parts.
- Relate previously learned concepts to new concepts.
- Look for similarities among problems.
- Connect solutions of problems to more complicated large-scale situations.

Clarifications:

Teachers who encourage students to use patterns and structure to help understand and connect mathematical concepts:

- Help students recognize the patterns in the world around them and connect these patterns to mathematical concepts.
- Support students to develop generalizations based on the similarities found among problems.
- Provide opportunities for students to create plans and procedures to solve problems.
- Develop students' ability to construct relationships between their current understanding and more sophisticated ways of thinking.

MA.K12.MTR.6.1 Assess the reasonableness of solutions.

Mathematicians who assess the reasonableness of solutions:

- Estimate to discover possible solutions.
- Use benchmark quantities to determine if a solution makes sense.
- Check calculations when solving problems.
- Verify possible solutions by explaining the methods used.
- Evaluate results based on the given context.

Clarifications:

Teachers who encourage students to assess the reasonableness of solutions:

- Have students estimate or predict solutions prior to solving.
- Prompt students to continually ask, "Does this solution make sense? How do you know?"
- Reinforce that students check their work as they progress within and after a task.
- Strengthen students' ability to verify solutions through justifications.

MA.K12.MTR.7.1 Apply mathematics to real-world contexts.

Mathematicians who apply mathematics to real-world contexts:

- Connect mathematical concepts to everyday experiences.
- Use models and methods to understand, represent and solve problems.
- Perform investigations to gather data or determine if a method is appropriate.
- Redesign models and methods to improve accuracy or efficiency.

Clarifications:

Teachers who encourage students to apply mathematics to real-world contexts:

- Provide opportunities for students to create models, both concrete and abstract, and perform investigations.
- Challenge students to question the accuracy of their models and methods.
- Support students as they validate conclusions by comparing them to the given situation.
- Indicate how various concepts can be applied to other disciplines.

Examples of Teacher and Student Moves for the MTRs

Below are examples that demonstrate the embedding of the MTRs within the mathematics classroom. The provided teacher and student moves are examples of how some MTRs could be incorporated into student learning and instruction keeping in mind the benchmark(s) that are the focal point of the lesson or task. The information included in this table is not a comprehensive list, and educators are encouraged to incorporate other teacher and student moves that support the MTRs.

MTR	Student Moves	Teacher Moves
<p>MA.K12.MTR.1.1 <i>Actively participate in effortful learning both individually and collectively.</i></p>	<ul style="list-style-type: none"> • Students engage in the task through individual analysis, student-to-teacher interaction and student-to-student interaction. • Students ask task-appropriate questions to self, the teacher and to other students. (<i>MTR.4.1</i>) • Students have a positive productive struggle exhibiting growth mindset, even when making a mistake. • Students stay engaged in the task to a purposeful conclusion while modifying methods, when necessary, in solving a problem through self-analysis and perseverance. 	<ul style="list-style-type: none"> • Teacher provides flexible options (i.e., differentiated, challenging tasks that allow students to actively pursue a solution both individually and in groups) so that all students have the opportunity to access and engage with instruction, as well as demonstrate their learning. • Teacher creates a physical environment that supports a growth mindset and will ensure positive student engagement and collaboration. • Teacher provides constructive, encouraging feedback to students that recognizes their efforts and the value of analysis and revision. • Teacher provides appropriate time for student processing, productive struggle and reflection. • Teacher uses data and questions to focus students on their thinking; help students determine their sources of struggle and to build understanding. • Teacher encourages students to ask appropriate questions of other students and of the teacher including questions that examine accuracy. (<i>MTR.4.1</i>)

MTR	Student Moves	Teacher Moves
<p>MA.K12.MTR.2.1 <i>Demonstrate understanding by representing problems in multiple ways.</i></p>	<ul style="list-style-type: none"> • Students represent problems concretely using objects, models and manipulatives. • Students represent problems pictorially using drawings, models, tables and graphs. • Students represent problems abstractly using numerical or algebraic expressions and equations. • Students make connections and select among different representations and methods for the same problem, as appropriate to different situations or context. <i>(MTR.3.1)</i> 	<ul style="list-style-type: none"> • Teacher provides students with objects, models, manipulatives, appropriate technology and real-world situations. <i>(MTR.7.1)</i> • Teacher encourages students to use drawings, models, tables, expressions, equations and graphs to represent problems and solutions. • Teacher questions students about making connections between different representations and methods and challenges students to choose one that is most appropriate to the context. <i>(MTR.3.1)</i> • Teacher encourages students to explain their different representations and methods to each other. <i>(MTR.4.1)</i> • Teacher provides opportunities for students to choose appropriate methods and to use mathematical technology.
<p>MA.K12.MTR.3.1 <i>Complete tasks with mathematical fluency.</i></p>	<ul style="list-style-type: none"> • Students complete tasks with flexibility, efficiency and accuracy. • Students use feedback from peers and teachers to reflect on and revise methods used. • Students build confidence through practice in a variety of contexts and problems. <i>(MTR.1.1)</i> 	<ul style="list-style-type: none"> • Teacher provides tasks and opportunities to explore and share different methods to solve problems. <i>(MTR.1.1)</i> • Teacher provides opportunities for students to choose methods and reflect (i.e., through error analysis, revision, summarizing methods or writing) on the efficiency and accuracy of the method(s) chosen. • Teacher asks questions and gives feedback to focus student thinking to build efficiency of accurate methods. • Teacher offers multiple opportunities to practice generalizable methods.

MTR	Student Moves	Teacher Moves
<p>MA.K12.MTR.4.1 <i>Engage in discussions that reflect on the mathematical thinking of self and others.</i></p>	<ul style="list-style-type: none"> • Students use content specific language to communicate and justify mathematical ideas and chosen methods. • Students use discussions and reflections to recognize errors and revise their thinking. • Students use discussions to analyze the mathematical thinking of others. • Students identify errors within their own work and then determine possible reasons and potential corrections. • When working in small groups, students recognize errors of their peers and offers suggestions. 	<ul style="list-style-type: none"> • Teacher provides students with opportunities (through open-ended tasks, questions and class structure) to make sense of their thinking. <i>(MTR.1.1)</i> • Teacher uses precise mathematical language, both written and abstract, and encourages students to revise their language through discussion. • Teacher creates opportunities for students to discuss and reflect on their choice of methods, their errors and revisions and their justifications. • Teachers select, sequence and present student work to elicit discussion about different methods and representations. <i>(MTR.2.1, MTR.3.1)</i>
<p>MA.K12.MTR.5.1 <i>Use patterns and structure to help understand and connect mathematical concepts.</i></p>	<ul style="list-style-type: none"> • Students identify relevant details in a problem in order to create plans and decompose problems into manageable parts. • Students find similarities and common structures, or patterns, between problems in order to solve related and more complex problems using prior knowledge. 	<ul style="list-style-type: none"> • Teacher asks questions to help students construct relationships between familiar and unfamiliar problems and to transfer this relationship to solve other problems. <i>(MTR.1.1)</i> • Teacher provides students opportunities to connect prior and current understanding to new concepts. • Teacher provides opportunities for students to discuss and develop generalizations about a mathematical concept. <i>(MTR.3.1, MTR.4.1)</i> • Teacher allows students to develop an appropriate sequence of steps in solving problems. • Teacher provides opportunities for students to reflect during problem solving to make connections to problems in other contexts, noticing structure and making improvements to their process.

MTR	Student Moves	Teacher Moves
<p>MA.K12.MTR.6.1 <i>Assess the reasonableness of solutions.</i></p>	<ul style="list-style-type: none"> • Students estimate a solution, including using benchmark quantities in place of the original numbers in a problem. • Students monitor calculations, procedures and intermediate results during the process of solving problems. • Students verify and check if solutions are viable, or reasonable, within the context or situation. <i>(MTR.7.1)</i> • Students reflect on the accuracy of their estimations and their solutions. 	<ul style="list-style-type: none"> • Teacher provides opportunities for students to estimate or predict solutions prior to solving. • Teacher encourages students to compare results to estimations and revise if necessary for future situations. <i>(MTR.5.1)</i> • Teacher prompts students to self-monitor by continually asking, “Does this solution or intermediate result make sense? How do you know?” • Teacher encourages students to provide explanations and justifications for results to self and others. <i>(MTR.4.1)</i>
<p>MA.K12.MTR.7.1 <i>Apply mathematics to real-world contexts.</i></p>	<ul style="list-style-type: none"> • Students connect mathematical concepts to everyday experiences. • Students use mathematical models and methods to understand, represent and solve real-world problems. • Students investigate, research and gather data to determine if a mathematical model is appropriate for a given situation from the world around them. • Students re-design models and methods to improve accuracy or efficiency. 	<ul style="list-style-type: none"> • Teacher provides real-world context to help students build understanding of abstract mathematical ideas. • Teacher encourages students to assess the validity and accuracy of mathematical models and situations in real-world context, and to revise those models if necessary. • Teacher provides opportunities for students to investigate, research and gather data to determine if a mathematical model is appropriate for a given situation from the world around them. • Teacher provides opportunities for students to apply concepts to other content areas.

Grade 5 Areas of Emphasis

In grade 5, instructional time will emphasize five areas:

- (1) multiplying and dividing multi-digit whole numbers, including using a standard algorithm;
- (2) adding and subtracting fractions and decimals with procedural fluency, developing an understanding of multiplication and division of fractions and decimals;
- (3) developing an understanding of the coordinate plane and plotting pairs of numbers in the first quadrant;
- (4) extending geometric reasoning to include volume; and
- (5) extending understanding of data to include the mean.

The purpose of the areas of emphasis is not to guide specific units of learning and instruction, but rather provide insight on major mathematical topics that will be covered within this mathematics course. In addition to its purpose, the areas of emphasis are built on the following.

- Supports the intentional horizontal progression within the strands and across the strands in this grade level or course.
- Student learning and instruction should not focus on the stated areas of emphasis as individual units.
- Areas of emphasis are addressed within standards and benchmarks throughout the course so that students are making connections throughout the school year.
- Some benchmarks can be organized within more than one area.
- Supports the communication of the major mathematical topics to all stakeholders.
- Benchmarks within the areas of emphasis should not be taught within the order in which they appear. To do so would strip the progression of mathematical ideas and miss the opportunity to enhance horizontal progressions within the grade level or course.

The table below shows how the benchmarks within this mathematics course are embedded within the areas of emphasis.

		Multiplying and dividing multi-digit whole numbers	Adding and subtracting fractions and decimals, multiplication and division of fractions and decimals	Developing understanding of the coordinate plane	Extending geometric reasoning to include volume	Extending understanding of data to include mean
Number Sense and Operations	MA.5.NSO.1.1		X			
	MA.5.NSO.1.2		X			
	MA.5.NSO.1.3		X			
	MA.5.NSO.1.4		X			
	MA.5.NOS.1.5		X			
	MA.5.NSO.2.1	X				
	MA.5.NSO.2.2	X				
	MA.5.NSO.2.3		X			
	MA.5.NSO.2.4		X			
	MA.5.NSO.2.5		X			

		Multiplying and dividing multi-digit whole numbers	Adding and subtracting fractions and decimals, multiplication and division of fractions and decimals	Developing understanding of the coordinate plane	Extending geometric reasoning to include volume	Extending understanding of data to include mean
Fractions	MA.5.FR.1.1		X			
	MA.5.FR.2.1		X			
	MA.5.FR.2.2		X			
	MA.5.FR.2.3		X			
	MA.5.FR.2.4		X			
Algebraic Reasoning	MA.5.AR.1.1	X				
	MA.5.AR.1.2		X			
	MA.5.AR.1.3		X			
	MA.5.AR.2.1	X	X			
	MA.5.AR.2.2	X	X			
	MA.5.AR.2.3	X				
	MA.5.AR.2.4	X				
	MA.5.AR.3.1	X				
	MA.5.AR.3.2	X				
Measurement	MA.5.M.1.1	X	X		X	
	MA.5.M.2.1	X	X		X	
Geometric Reasoning	MA.5.GR.1.1				X	
	MA.5.GR.1.2				X	
	MA.5.GR.2.1		X		X	
	MA.5.GR.3.1				X	
	MA.5.GR.3.2				X	
	MA.5.GR.3.3				X	
	MA.5.GR.4.1			X		
	MA.5.GR.4.2			X		
Data Analysis & Probability	MA.5.DP.1.1		X			X
	MA.5.DP.1.2		X			X

Number Sense and Operations

MA.5.NSO.1 *Understand the place value of multi-digit numbers with decimals to the thousandths place.*

MA.5.NSO.1.1

Benchmark

MA.5.NSO.1.1 Express how the value of a digit in a multi-digit number with decimals to the thousandths changes if the digit moves one or more places to the left or right.

Connecting Benchmarks/Horizontal Alignment

- MA.5.NSO.2.4, MA.5.NSO.2.5
- MA.5.AR.2.1, MA.5.AR.2.2, MA.5.AR.2.3
- MA.5.M.1.1
- MA.5.M.2.1

Terms from the K-12 Glossary

Vertical Alignment

Previous Benchmarks

- MA.4.NSO.1.1

Next Benchmarks

- MA.6.NSO.2.1

Purpose and Instructional Strategies

This purpose of this benchmark is for students to reason about the magnitude of digits in a number. This benchmark extends the understanding from grade 4 (MA.4.NSO.1.1), where students expressed their understanding that in multi-digit whole numbers, a digit in one place represents 10 times what it represents in the place to its right and $\frac{1}{10}$ of what it represents in the place to its left. All of this work forms the foundation for arithmetic and algorithms with decimals which is completed in grade 6 (MA.6.NSO.2.1).

- To help students understand the meaning of the *10 times* and $\frac{1}{10}$ of relationship, students can use base ten manipulatives or simply bundle classroom objects (e.g., paper clips, pretzel sticks). Students should name numbers and use verbal descriptions to explain the relationship between numbers (e.g., “6 is 10 times greater than 6 tenths, and 6 tenths is $\frac{1}{10}$ of 6”). In addition to physical manipulatives, place value charts help students understand the relationship between digits in different places (*MTR.2.1*).
- Instruction of this benchmark should connect with student work with whole numbers. For example, students who understand $35 \times 2 = 70$ can reason that $3.5 \times 2 = 7$ because 3.5 is $\frac{1}{10}$ of 35, therefore its product with 2 will be $\frac{1}{10}$ of 70 (*MTR.5.1*).

Common Misconceptions or Errors

- Students can misunderstand what “ $\frac{1}{10}$ of” a number represents. Teachers can connect $\frac{1}{10}$ of to “ten times less” or “dividing by 10” to help students connect $\frac{1}{10}$ of a number to 10 times greater.
- Students who use either rule “move the decimal point” or “shift the digits” without understanding when multiplying by a power of ten can easily make errors. Students need to understand that from either point of view, the position of the decimal point marks the transition between the ones and the tenths place.

Strategies to Support Tiered Instruction

- Instruction includes the use of place value charts and models such as place value disks to demonstrate how the value of a digit changes if the digit moves one place to the left or right. Explicit instruction includes using place value understanding to make the connections between the concepts of “ $\frac{1}{10}$ of,” “ten times less” and “dividing by 10.” Place value charts are used to demonstrate that the decimal point marks the transition between the ones place and the tenths place.
 - For example, students multiply 4 by 10, then record 4 and the product of 40 in a place value chart. This process is repeated by multiplying 40 by 10 while asking students to explain what happens to the digit 4 each time it is multiplied by 10. Next, the teacher explains that multiplying by $\frac{1}{10}$ is the same as dividing by 10. Students multiply 400 by $\frac{1}{10}$ and record the product in their place value chart. This process is repeated, multiplying 40 and 4 by $\frac{1}{10}$. The teacher asks students to explain how the value of the 4 changed when being multiplied by 10 and $\frac{1}{10}$.

tens	ones	tenths	hundredths	thousandths
		4		
	4			
4				
	4			
		4		
			4	
				4

- For example, instruction includes using a familiar context such as money, asking students to explain the value of each digit in \$33.33. Next, students represent 33.33 in a place value chart using place value disks. Then, students compare the value of the whole numbers (3 dollars and 30 dollars) and compare 0.3 and 0.03 (30 cents and 3 cents). The teacher asks, “How does the value of the three in the hundredths place compare to the value of the three in the tenths place?” and

explains that the three in the hundredths place is $\frac{1}{10}$ the value of the three in the tenths place and that multiplying by $\frac{1}{10}$ is the same as dividing by 10.

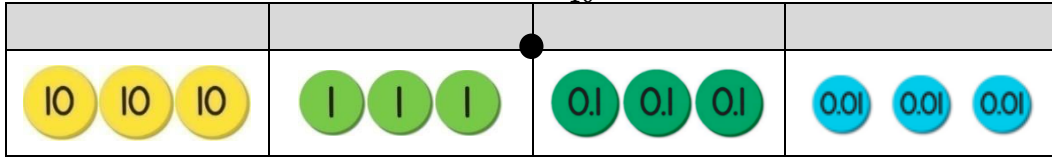

Instructional Tasks

Instructional Task 1 (MTR.7.1)

At the Sunshine Candy Store, salt water taffy costs \$0.18 per piece.

Part A. How much would 10 pieces of candy cost?

Part B. How much would 100 pieces of candy cost?

Part C. How much would 1000 pieces of candy cost?

Part D. At the same store, you can buy 100 chocolate coins for \$89.00. How much does each chocolate coin cost? Explain how you know.

Instructional Items

Instructional Item 1

Which statement correctly compares 0.034 and 34?

a. 0.034 is 10 times the value of 34.

b. 0.034 is $\frac{1}{10}$ the value of 34.

c. 0.034 is $\frac{1}{100}$ the value of 34.

d. 0.034 is $\frac{1}{1000}$ the value of 34.

Instructional Item 2

What number is 100 times the value of 45.03?

**The strategies, tasks and items included in the BIG-M are examples and should not be considered comprehensive.*

Benchmark

MA.5.NSO.1.2 Read and write multi-digit numbers with decimals to the thousandths using standard form, word form and expanded form.

Example: The number sixty-seven and three hundredths written in standard form is 67.03 and in expanded form is $60 + 7 + 0.03$ or $(6 \times 10) + (7 \times 1) + \left(3 \times \frac{1}{100}\right)$.

Connecting Benchmarks/Horizontal Alignment

Terms from the K-12 Glossary

- MA.5.NSO.2.4, MA.5.NSO.2.5
- MA.5.AR.2.1, MA.5.AR.2.2, MA.5.AR.2.3
- MA.5.M.2.1

Vertical Alignment

Previous Benchmarks

Next Benchmarks

- MA.4.NSO.1.2
- MA.6.AR.1.1

Purpose and Instructional Strategies

The purpose of this benchmark is for students to read numbers appropriately and to write numbers in all forms. Utilizing place value, students are expected to understand the value of tenths, hundredths, and thousandths, extending from their work to read and write whole numbers in any form in grade 4 (MA.4.NSO.1.2). Writing numbers in expanded form can help students see the relationship between decimals and fractions (*MTR.5.1*). Translating from written form to symbolic form builds the foundation for moving from written to algebraic form in grade 6 (MA.6.AR.1.1).

- Representing numbers in flexible ways will help students name, order, compare and operate with decimals (*MTR.3.1*).
- During instruction, teachers should relate all three forms using place value charts and base ten manipulatives (e.g., blocks) (*MTR.3.1, MTR.4.1, MTR.5.1*).

Common Misconceptions or Errors

- Students may incorrectly read and write from expanded form if one of the digits is 0, like in the number 67.03 as used in the benchmark example. A common mistake that students make is to name the number as 67.3 because they do not see that 3 is the value of hundredths.

Strategies to Support Tiered Instruction

- Instruction includes the use of place value understanding, models such as place value disks and decimal fractions to read and write multi-digit numbers with decimals to the thousandths using standard form, word form and expanded form when one of the digits in the decimal place values is 0.
 - For example, write 2.054 in standard form, word form and expanded form using a place value chart.

	Tens	ones	tenths	hundredths	thousandths
Standard Form		2	0	5	4

Place Value Disks			
Word Form	two and		Fifty – four thousandths
Expanded Form	$2 + 0.05 + 0.004$		
	$(2 \times 1) + (5 \times \frac{1}{100}) + (4 \times \frac{4}{1,000})$		

- For example, the teacher uses decimal fractions and a place value chart to help students read 2.054, modeling how to write the decimal portion of the number as a fraction, $\frac{54}{1,000}$ and explaining that doing so helps us to read the decimal correctly. Also, the teacher explains that the word “and” is used for a portion of a number, decimal or fraction. Next, the teacher and students write 2.054 as $2\frac{54}{1,000}$ and read the number as “two and fifty-four thousandths.”
- For example, write 6.03 in standard form, word form and expanded form using a place value chart.

	Ones	tenths	hundredths
Standard Form	6	0	3
Word Form	six and		three hundredths
Place Value Disks			
Expanded Form	$6 + 0.03$		
	$(6 \times 1) + (3 \times \frac{1}{100})$		

- For example, the teacher uses decimal fractions and a place value chart to help students read 6.03, while modeling how to write the decimal portion of the number as a fraction, $\frac{3}{100}$ and explaining that doing so helps us to read the decimal correctly. Also, the teacher explains that the word “and” is used for a portion of a number, decimal or fraction. Next, write 6.03 as $6\frac{3}{100}$ and read the number as “six and three hundredths.”

Instructional Tasks

Instructional Task 1

Use the number cards below to write a number in standard, word and expanded forms. You can use the cards in any order to make your number, but it must have a digit other than zero in the thousandths place.

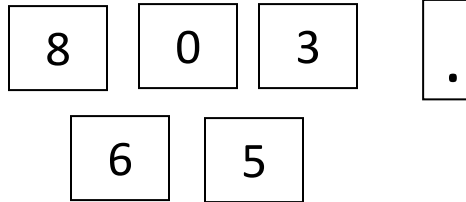

Instructional Items

Instructional Item 1

Which shows the number below in word form?

$$(7 \times 100) + (2 \times 1) + \left(5 \times \frac{1}{10}\right) + \left(9 \times \frac{1}{1000}\right)$$

- Seventy – two and fifty – nine thousandths
- Seven hundred two and fifty – nine hundredths
- Seven hundred two and five hundred nine thousandths
- Seventy – two and five hundred nine thousandths

Instructional Item 2

Write *eight thousand and 2 hundredths* in standard form.

**The strategies, tasks and items included in the BIG-M are examples and should not be considered comprehensive.*

MA.5.NSO.1.3

Benchmark

MA.5.NSO.1.3

Compose and decompose multi-digit numbers with decimals to the thousandths in multiple ways using the values of the digits in each place. Demonstrate the compositions or decompositions using objects, drawings and expressions or equations.

Example: The number 20.107 can be expressed as 2 tens + 1 tenth + 7 thousandths or as 20 ones + 107 thousandths.

Connecting Benchmarks/Horizontal Alignment

Terms from the K-12 Glossary

- MA.5.NSO.2.4, MA.5.NSO.2.5
- MA.5.AR.2.1, MA.5.AR.2.2, MA.5.AR.2.3
- MA.5.M.2.1

Vertical Alignment

Previous Benchmarks

Next Benchmarks

Purpose and Instructional Strategies

The purpose of this benchmark is for students to use place value relationships to compose and decompose multi-digit numbers with decimals. While students have composed and decomposed whole numbers in grade 3 (MA.3.NSO.1.2) and fractions in grade 4 (MA.4.FR.2.1), naming multi-digit decimals in flexible ways in grade 5 helps students with decimal comparisons and operations (addition, subtraction, multiplication and division). Flexible representations of multi-digit numbers with decimals also reinforces the understanding of how the value of digits change if they move one or more places left or right (MA.5.NSO.1.1). Composing and decomposing numbers also helps build the foundation for further work with the distributive property in grade 6 (MA.6.NSO.3.2).

- Instruction may include multiple representations using base ten models (*MTR.2.1*). During instruction, teachers should emphasize that the value of a base ten block (or another concrete model) is flexible (e.g., one flat could be 1 ten, one, tenth, hundredth, and so forth). Using base ten models flexibly helps students think about how numbers can be composed and decomposed in different ways.
 - For example, the image below shows 2.1. This representation shows that 2.1 can also be composed as 21 *tenths* or 210 *hundredths*. Thinking about 2.1 as 210 *hundredths* may help subtracting $2.1 - 0.04$ easier for students because they can think about the expression as 210 *hundredths minus 4 hundredths*, or 206 *hundredths*.

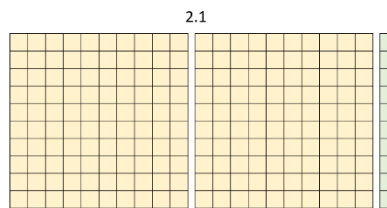

- Representing multi-digit numbers with decimals flexibly can help students reason through multiplication and division as well. For example, students may prefer to multiply 1.2×4 as 12 *tenths* $\times 4$ to use more familiar numbers (*MTR.2.1, MTR.5.1*).
- Students should name their representations in different forms (e.g., word, expanded) during classroom discussion. While students are representing multi-digit numbers with decimals in different ways, teachers should invite all answers and have students compare them (*MTR.4.1*).

Common Misconceptions or Errors

- Students may assume that the value of base ten blocks are fixed based on their previous experiences with whole numbers (e.g., units are ones, rods are tens, flats are hundreds). During instruction, teachers should name a base ten block for each example so students can relate the other blocks. (For example, “Show 2.4. Allow 1 rod to represent 1 tenth.”)

Strategies to Support Tiered Instruction

- Instruction includes opportunities to decompose multi-digit numbers with decimals to the hundredths in multiple ways. Instruction includes the use of base-ten blocks to represent decimals where one flat represents one whole, one rod represents one tenth and one unit represents one hundredth. During instruction, the teacher names a base ten block for each example, so students relate the other blocks. A chart can be used to organize students' thinking. The teacher asks students to identify the different ways to name the values (grouping the hundredths into tenths and the tenths into the ones, e.g., *2 ones* and *34 hundredths* or *20 tenths* and *34 hundredths*, etc.)

- For example, decompose 2.34 in multiple ways using ones, tenths and hundredths.

2.34			
	Example 1	Example 2	Example 3
Ones and tenths	Not applicable for this example		
Ones and hundredths	<i>2 ones + 34 hundredths</i>		
Ones, tenths and hundredths	<i>2 ones + 3 tenths + 4 hundredths</i>	<i>1 one + 13 tenths + 4 hundredths</i>	<i>2 ones + 2 tenths + 14 hundredths</i>
Tenths and hundredths	<i>23 tenths + 4 hundredths</i>	<i>22 tenths + 14 hundredths</i>	<i>20 tenths + 34 hundredths</i>
Hundredths only	<i>234 hundredths</i>		

- For example, show 3.5. Allow one rod to represent one-tenth. Then, decompose 3.5 in multiple ways using ones, tenths and hundredths.

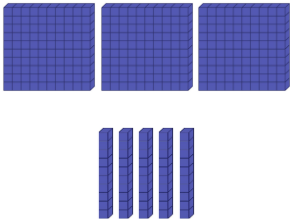
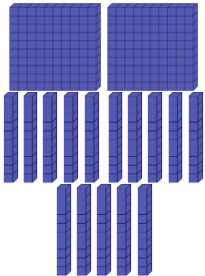
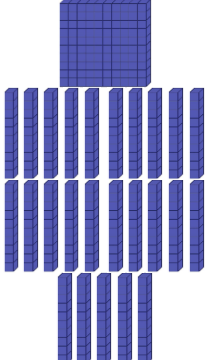
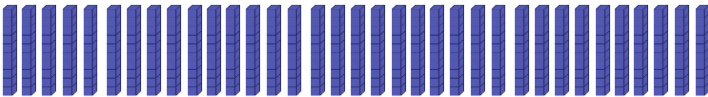
3.5			
	Example 1	Example 2	Example 3
Ones and tenths	<p><i>3 ones + 5 tenths</i></p> 	<p><i>2 ones + 15 tenths</i></p> 	<p><i>1 ones + 25 tenths</i></p> 
Tenths only	<p><i>35 tenths</i></p> 		

Instructional Tasks

Instructional Task 1 (MTR.2.1)

Using base ten blocks, show 1.36 in two different ways. Allow one flat to represent 1 whole.

Instructional Task 2 (MTR.3.1)

How many tenths are equivalent to 13.2? How do you know?

Instructional Items

Instructional Item 1

Select all the ways to name 14.09.

- a. 1,409 *hundredths*
- b. 1 *ten* + 409 *hundredths*
- c. 1 *ten* + 4 *ones* + 9 *tenths*
- d. 140 *tenths* + 9 *hundredths*
- e. 1,409 *tenths*

**The strategies, tasks and items included in the BIG-M are examples and should not be considered comprehensive.*

MA.5.NSO.1.4

Benchmark

MA.5.NSO.1.4 Plot, order and compare multi-digit numbers with decimals up to the thousandths.

Example: The numbers 4.891, 4.918 and 4.198 can be arranged in ascending order as 4.198, 4.891 and 4.918.

Example: $0.15 < 0.2$ because *fifteen hundredths* is less than *twenty hundredths*, which is the same as *two tenths*.

Benchmark Clarifications:

Clarification 1: When comparing numbers, instruction includes using an appropriately scaled number line and using place values of digits.

Clarification 2: Scaled number lines must be provided and can be a representation of any range of numbers.

Clarification 3: Within this benchmark, the expectation is to use symbols ($<$, $>$ or $=$).

Connecting Benchmarks/Horizontal Alignment

Terms from the K-12 Glossary

- MA.5.NSO.2.4, MA.5.NSO.2.5
- MA.5.AR.2.1, MA.5.AR.2.2, MA.5.AR.2.3

Vertical Alignment

Previous Benchmarks

- MA.4.NSO.1.3, MA.4.NSO.1.5

Next Benchmarks

- MA.6.NSO.1.1

Purpose and Instructional Strategies

The purpose of this benchmark is for students to use place value understanding to plot, order and compare multi-digit numbers with decimals to the thousandths. In grade 4 (MA.4.NSO.1.5), decimals were plotted to the hundredths, and in grade 6 (MA.6.NSO.1.1) rational numbers, including negative numbers, will be plotted.

- During instruction, students should apply understanding of flexible representations from MA.5.NSO.1.3 to help them reason while plotting, ordering and comparing.
- During instruction, teachers should show students how to represent these decimals on scaled number lines. Students should use place value understanding to make comparisons.
- Instruction expects students to justify their arguments when plotting, comparing and ordering (*MTR.4.1*).

Common Misconceptions or Errors

- Students may be confused when comparing numbers that have the same digits (but different values).
 - For example, when comparing 2.459 and 13.24, a student may not consider the magnitude of the numbers and only look at their digits. That student may claim that 2.459 is greater than 13.24 because the digit 2 is greater than the digit 1 (though they are actually comparing 2 and 10).

Strategies to Support Tiered Instruction

- Instruction includes the use of place value charts, number lines and relational symbols to compare numbers to the thousandths that have the same amount of digits but different values. It is imperative for students to develop a conceptual understanding of rounding, such as what the benchmarks are, using place value understanding to round numbers without instruction of mnemonics, rhymes or songs.
 - For example, when comparing 7.468 and 23.15, students record 7.468 and 23.15 in a place value chart. The teacher asks students to compare these numbers, beginning with the greatest place value and explains that the number 23.15 has 2 *tens* and the number 7.468 does not have any *tens* so $7.468 < 23.15$ and $23.15 > 7.468$ even though both numbers have the same amount of digits. Also, students plot 7.468 and 23.15 on a number line to compare the magnitude of the numbers.

Tens	ones	tenths	hundredths	thousandths
	7	4	6	8
2	3	1	5	

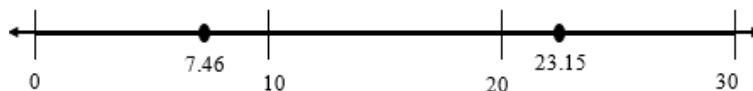

- For example, when comparing 12.3 and 9.57 students record 12.3 and 9.57 in a place value chart. The teacher asks students to compare these numbers, beginning with the greatest place value while explaining that the number 12.3 has one *ten* and the number 9.57 does not have any *tens* so $9.57 < 12.3$ and $12.3 > 9.57$ even though both numbers have the same amount of digits. Also, students plot 12.3 and 9.57 on a number line to compare the magnitude of the numbers.

		tenths	hundredths
(1)	2	3	
	9	5	7

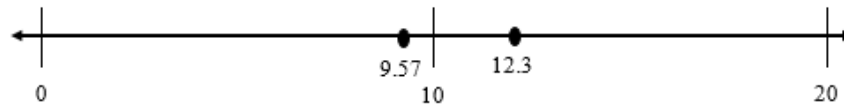

Instructional Tasks

Instructional Task 1 (MTR.3.1)

Part A. Plot the numbers 1.519, 1.9, 1.409 and 1.59 on the number line below.

Part B. Choose two values from the list and compare them using $>$, $<$ or $=$.

Part C. Choose a number between 1.519 and 1.59 and plot it on the number line.

Part D. Use evidence from your number line to justify which number is greatest.

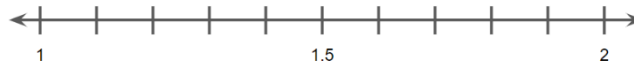

Instructional Items

Instructional Item 1

Select all the statements that are true.

- $13.049 < 13.49$
- $13.049 < 13.05$
- $2.999 > 28.99$
- $1.28 < 1.31$
- $5.800 = 5.8$

**The strategies, tasks and items included in the BIG-M are examples and should not be considered comprehensive.*

MA.5.NSO.1.5

Benchmark

MA.5.NSO.1.5 Round multi-digit numbers with decimals to the thousandths to the nearest hundredth, tenth or whole number.

Example: The number 18.507 rounded to the nearest tenth is 18.5 and to the nearest hundredth is 18.51.

Connecting Benchmarks/Horizontal Alignment

- MA.5.NSO.2.4, MA.5.NSO.2.5
- MA.5.AR.2.1, MA.5.AR.2.2, MA.5.AR.2.3

Terms from the K-12 Glossary

Vertical Alignment

Previous Benchmarks

- MA.4.NSO.1.4

Next Benchmarks

- MA.6.NSO.2.3
- MA.8.NSO.1.4

Purpose and Instructional Strategies

The purpose of this benchmark is for students to think about the magnitude of multi-digit numbers with decimals to round them to the nearest hundredth, tenth or whole number. In grade 5, the expectations for rounding are to the nearest hundredth and to digits other than the leading digit, e.g., round 29.834 to the nearest hundredth. Students have experience rounding whole numbers to any place in grade 4 (MA.4.NSO.1.4). Rounding skills continue to be important in later grades as students solve real-world problems with fractions and decimals (MA.6.NSO.2.3) and work with scientific notation (MA.8.NSO.1.4).

- Instruction develops some efficient rules for rounding fluently by building from the basic strategy of – “Is 29.834 closer to 20 or 30?” Number lines are effective tools for this type of thinking and help students relate the placement of numbers to benchmarks for rounding (*MTR.3.1, MTR.5.1*).
- The expectation is that students have a deep understanding of place value and number sense in order to develop and use an algorithm or procedure for rounding. Additionally, students should explain and reason about their answers when they round and have numerous experiences using a number line and a hundred chart as tools to support their work with rounding.

Common Misconceptions or Errors

- Students may confuse benchmarks by which numbers can round.
 - For example, when rounding 29.834 to the nearest tenth, they may confuse that the benchmarks are 29.8 and 29.9. The reliance on mnemonics, songs or rhymes during instruction can often confuse students further because it may replace their motivation to think about the benchmark numbers.

Strategies to Support Tiered Instruction

- Instruction includes using number lines and place value understanding to round multi-digit numbers with decimals to the nearest tenth or whole number.

- For example, students round 16.32 to the nearest tenth using a number line and place value understanding. The teacher explains that the endpoints of the number line will be represented using tenths, because we are rounding to the nearest tenth. The teacher explains that there are three tenths in the number 16.32 and one more tenth would be four tenths. The teacher represents these endpoints on the number line as sixteen and three-tenths (16.3) and sixteen and four-tenths (16.4) while reminding students that 16.3 is equivalent to 16.30 and 16.4 is equivalent to 16.40. Additionally, the teacher explains that the mid-point on the number line can be labeled as sixteen and three-tenths, five-hundredths or sixteen and 35 hundredths (16.35). This midpoint is halfway between 16.3 and 16.4. The teacher asks students to plot 16.32 on the number line and discuss if it is closer to 16.3 or 16.4, explaining that 16.32 rounds to 16.3 because it is less than the midpoint of 16.35 and closer to 16.3 on the number line.

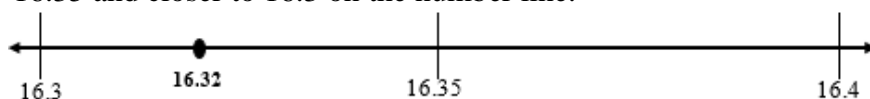

- For example, students round 6.8 to the nearest whole number using a number line and place value understanding. The teacher explains that the endpoints of our number line will be represented using ones, because we are rounding to the nearest whole number. Also, the teacher explains that there are six ones in the number 6.8 and one more one would be seven ones. The teacher represents these endpoints on the number line as six ones (6) and seven ones (7). The midpoint on the number line is labeled as 6 ones and 5 tenths (6.5). This midpoint is halfway between 6 and 7. The teacher asks students to plot 6.8 on the number line and discuss if it is closer to six or seven, explaining that 6.8 rounds to seven because it is eight-tenths away from six and only two-tenths away from seven. It is also less than the midpoint of 6.5.

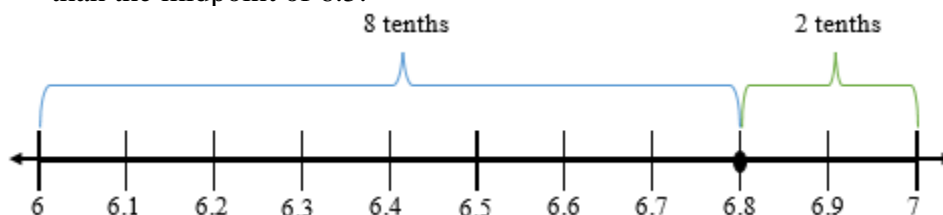

Instructional Tasks

Instructional Task 1 (MTR.3.1, MTR.6.1)

Round 29.834 to the nearest whole number. Identify between which two whole numbers 29.834 lies on a number line.

Instructional Task 2 (MTR.3.1, MTR.6.1)

Round 29.834 to the nearest *tenth*. Identify between which *two tenths* 29.834 lies on a number line.

Instructional Task 3 (MTR.3.1, MTR.6.1)

Round 29.834 to the nearest *hundredth*. Identify between which *two hundredths* 29.834 lies on a number line.

Instructional Items

Instructional Item 1

Which of the following are true about the number 104.029?

- a. 104.029 rounded to the nearest whole number is 4.
- b. 104.029 rounded to the nearest whole number is 104.
- c. 104.029 rounded to the nearest *tenth* is 104.2.
- d. 104.029 rounded to the nearest *hundredth* is 104.02.
- e. 104.029 rounded to the nearest *hundredth* is 104.03.

**The strategies, tasks and items included in the BIG-M are examples and should not be considered comprehensive.*

MA.5.NSO.2 *Add, subtract, multiply and divide multi-digit numbers.*

MA.5.NSO.2.1

Benchmark

MA.5.NSO.2.1 Multiply multi-digit whole numbers including using a standard algorithm with procedural fluency.

Connecting Benchmarks/Horizontal Alignment

- MA.5.FR.2.2
- MA.5.AR.1.1
- MA.5.M.1.1
- MA.5.GR.3

Terms from the K-12 Glossary

- Equation
- Expression
- Whole Number

Vertical Alignment

Previous Benchmarks

- MA.4.NSO.2.1, MA.4.NSO.2.2

Next Benchmarks

- MA.6.NSO.2.1

Purpose and Instructional Strategies

The purpose of this benchmark is for students to demonstrate procedural fluency while multiplying multi-digit whole numbers. To demonstrate procedural fluency, students may choose the standard algorithm that works best for them and demonstrates their procedural fluency. A standard algorithm is a method that is efficient and accurate (*MTR.3.1*). In grade 4, students had experience multiplying two-digit by three-digit numbers using a method of their choice with procedural reliability (MA.4.NSO.2.2) and multiplying two-digit by two-digit numbers using a standard algorithm (MA.4.NSO.2.3). In grade 6, students will multiply and divide multi-digit numbers including decimals with fluency (MA.6.NSO.2.1).

- There is no limit on the number of digits for multiplication in grade 5.
- When students use a standard algorithm, they should be able to justify why it works conceptually. Teachers can expect students to demonstrate how their algorithm works, for example, by comparing it to another method for multiplication (*MTR.6.1*).
- Along with using a standard algorithm, students should estimate reasonable solutions before solving. Estimation helps students anticipate possible answers and evaluate whether their solutions make sense after solving.
- This benchmark supports students as they solve multi-step real-world problems involving combinations of operations with whole numbers (MA.5.AR.1.1).

Common Misconceptions or Errors

- Students can make computational errors while using standard algorithms when they cannot reason why their algorithms work. In addition, they can struggle to determine where or why that computational mistake occurred because they did not estimate reasonable values for intermediate outcomes as well as for the final outcome. During instruction, teachers should expect students to justify their work while using their chosen algorithms and engage in error analysis activities to connect their understanding to the algorithm.

Strategies to Support Tiered Instruction

- Instruction includes estimating reasonable values for partial products as well as final products.
 - For example, students make reasonable estimates for the partial products and final product for 513×32 . Before using an algorithm, students can make estimates for partial products and final product to make sure that they are using the algorithm correctly and the answer is reasonable. First, students will estimate the first partial product by rounding 513 to the nearest hundred, 500, and multiplying by 2. When using an algorithm to solve the first partial product, the answer should be approximately 1,000. Next, students can estimate the second partial product by rounding 513 to 500 and multiplying by 30. When using an algorithm to solve the second partial product, it should be approximately 15,000. Finally, students can add the estimates for the partial products to find an estimate for the final product.

	5	0	0	→		513 rounded to the nearest hundred
×		3	2			
	1	0	0	=	2 × 500	→ first partial product estimate
+	1	5	0	=	30 × 500	→ second partial product estimate
	1	6	0	0	→	final product estimate

- For example, students make reasonable estimates for the partial products and final product for 41×23 . Before using an algorithm, students can make estimates for our partial products and final product to make sure that they are using the algorithm correctly and the answer is reasonable. First, students will estimate the first partial product by rounding 41 to 40 and multiplying by 3. When using an algorithm to determine the first partial product, it should be approximately 120. Next, students will estimate the second partial product by rounding 41 to 40 and multiplying by 20. When using an algorithm to determine the second partial product, it should be approximately 800. Finally, students can add the estimates for the partial products to find an estimate for the final product.

	4	0	→		41 rounded to the nearest ten	
×		2	3			
	1	2	0	=	3 × 40	→ first partial product estimate
+	8	2	0	=	20 × 40	→ second partial product estimate
	9	4	0	→	final product estimate	

- Instruction includes explaining and justifying mathematical reasoning while using a multiplication algorithm. Instruction includes determining if an algorithm was used correctly by analyzing any errors made and reviewing the reasonableness of solutions.
 - For example, students use an algorithm to determine 513×32 and explain their thinking using place value understanding. Begin by multiplying 2 ones times 3 ones; students should recognize this equals 6 ones. Students can write the 6 ones under the line, in the ones place. Next, multiply 2 ones times 1 ten, which students should recognize this equals 2 tens. They can write the 2 tens under the line in the tens place. Then, multiply 2 ones times 5 hundreds, which equals 10 hundreds. Write the 10 hundreds under the line in the thousands and hundreds place because 10 hundred is the same as 1 thousand. Students should see that this gives the first partial product of 1,026. Now multiply the 3 ones by the 3 tens from 32; this equals 9 tens or 90. Record 90 below the first partial product of 1,026. Next, multiply the 1 ten by 3 tens, which equal 3 hundreds, and write the 3 in the hundreds place of the second partial product. Then, multiply the 5 hundreds times 3 tens, which equals 15 thousands. Students can write the 15 in the ten thousands and thousands place of our second partial product, noticing that the second partial product is 15,390. Finally, add the partial products to find the product of 16,416.

$$\begin{array}{r}
 \\
 \\
 \times \\
 \hline
 + \\
 \\
 \\
 \hline
 \\
 \\
 \\
 \hline
 1
 \end{array}
 \quad
 \begin{array}{l}
 = 2 \times 513 \\
 = 30 \times 513 \Rightarrow \text{This is the same as } (3 \times 513) \times 10
 \end{array}$$

- For example, have students use an algorithm to determine 41×23 and explain their thinking using place value understanding. Explicit instruction could include “Begin by multiplying 3 ones times 1 one. This equals 3 ones. We will write the 3 ones under the line, in the ones place. Next, we will multiply 3 ones times 4 tens. This equals 12 tens. We will write the 12 tens under the line in the hundreds and tens place because 12 tens is the same as 1 hundred 2 tens. This gives us our first partial product of 123. Now we will multiply the 1 one by the 2 tens from 23. This equals 2 tens or 20. We will record 20 below our first partial product of 123. Next, we will multiply 2 tens times 4 tens, which equal 8 hundreds. We will write the 8 in the hundreds place of our second partial product. Our second partial product is 820. Finally, we add our partial products to get 943.”

$$\begin{array}{r}
 \\
 \\
 \times \\
 \hline
 + \\
 \\
 \\
 \hline
 \\
 \\
 \\
 \hline
 9
 \end{array}
 \quad
 \begin{array}{l}
 = 3 \times 41 \\
 = 20 \times 41 \Rightarrow \text{This is the same as } (2 \times 41) \times 10
 \end{array}$$

- For example, students solve 41×23 using an area model and place value understanding and explain how each partial product is calculated and what it represents as they multiply using the area model. Then, students explain how the final product is calculated using the partial products from the area model.

	20	3	+	1	2	0
40	$40 \times 20 = 800$	$40 \times 3 = 120$		9	4	3
1	$1 \times 20 = 20$	$1 \times 3 = 3$				

Instructional Tasks

Instructional Task 1 (MTR.7.1)

Maggie has three dogs. She buys a box containing 175 bags of dog food. Each bag weighs 64 ounces.

Part A. What is the total weight of the bags of dog food in ounces?

Part B. Maggie has a storage cart to transport the box that holds up to 750 pounds. Will the storage cart be able to hold the box? Explain.

Instructional Items

Instructional Item 1

What is the product of $1,834 \times 23$?

**The strategies, tasks and items included in the BIG-M are examples and should not be considered comprehensive.*

Benchmark

MA.5.NSO.2.2 Divide multi-digit whole numbers, up to five digits by two digits, including using a standard algorithm with procedural fluency. Represent remainders as fractions.

Example: The quotient $27 \div 7$ gives 3 with remainder 6 which can be expressed as $3\frac{6}{7}$.

Benchmark Clarifications:

Clarification 1: Within this benchmark, the expectation is not to use simplest form for fractions.

Connecting Benchmarks/Horizontal Alignment

- MA.5.FR.2.4
- MA.5.AR.1.1, MA.5.AR.1.3
- MA.5.M.1.1
- MA.5.GR.3.3

Terms from the K-12 Glossary

- Equation
- Expression
- Whole Number

Vertical Alignment

Previous Benchmarks

- MA.4.NSO.2.4

Next Benchmarks

- MA.6.NSO.2.1

Purpose and Instructional Strategies

The purpose of this benchmark is for students to demonstrate procedural fluency while dividing multi-digit whole numbers with up to 5-digit dividends and 2-digit divisors. To demonstrate procedural fluency, students may choose the standard algorithm that works best for them and demonstrates their procedural fluency. A standard algorithm is a method that is efficient and accurate (*MTR.3.1*). In grade 4, students had experience dividing four-digit by one-digit numbers using a method of their choice with procedural reliability (MA.4.NSO.2.4). In grade 6, students will multiply and divide multi-digit numbers including decimals with fluency (MA.6.NSO.2.1).

- When students use a standard algorithm, they should be able to justify why it works conceptually. Teachers can expect students to demonstrate how their algorithm works, for example, by comparing it to another method for division (*MTR.6.1*).
- In this benchmark, students are to represent remainders as fractions. In the benchmark example, the quotient of $27 \div 7$ is represented as $3\frac{6}{7}$. Students should gain understanding that this quotient means that there are 3 full groups of 7 in 27, and the remainder of 6 represents $\frac{6}{7}$ of another group. Students are not expected to have mastery of converting between forms (fraction, decimal, percentage) until grade 6 but students should start to gain familiarity that fractions and decimals are numbers and can be equivalent (i.e., a remainder of $\frac{1}{2}$ is the same as 0.5). Writing remainders as fractions or decimals is acceptable. Similarly, students should be able to understand that a remainder of zero means that whole groups have been filled without any of the dividend remaining (*MTR.5.1, MTR.7.1*).
- Along with using a standard algorithm, students should estimate reasonable solutions before solving. Estimation helps students anticipate possible answers and evaluate whether their solutions make sense after solving.
- This benchmark supports students as they solve multi-step real-world problems involving

- For example, connect place value with the partial quotients model to determine $94 \div 13$. Students should not just view the digits as individual numbers but connect individual digits with the value of that number (e.g., 94 is $90 + 4$). Instruction includes stating, “In this problem we are finding how many groups of 13 are in 94. We will subtract groups of 13 until we cannot subtract any more groups. The total number of groups that we can subtract is the quotient. We can subtract 7 groups of 13, so the quotient is 7. We have a remainder of 3. The quotient is represented as $7\frac{3}{13}$ because we have 7 full groups of 13 in 94 and the remainder of 3 represents $\frac{3}{13}$ of another group.”

$$\begin{array}{r}
 \overline{) 94} \\
 \underline{- 26} \quad 2 \text{ groups of } 13 \\
 68 \\
 \underline{- 26} \quad 2 \text{ groups of } 13 \\
 42 \\
 \underline{- 26} \quad 2 \text{ groups of } 13 \\
 16 \\
 \underline{- 13} \quad 1 \text{ group of } 13 \\
 3
 \end{array}$$

- For example, students use an algorithm to solve $496 \div 24$ and explain their thinking using place value understanding. Instruction includes stating, “In this problem we are finding how many groups of 24 are in 496. We will begin by dividing our largest place value first. Recognizing that the 4 represents 400, if you divide 400 by 24 the result will be less than 100, so the quotient won’t have any whole hundreds. Remember that 496 is the same as 49 *tens* 6 *ones*, so we will see how many groups of 24 are in 49 *tens*. We can also think of this as $__ \times 24 = 49 \text{ tens}$. There are 20 groups of 24 in 49 *tens*, that’s 2 times 10 groups, so we can place a 2 in the *tens* place of the quotient. Next, we will subtract 49 *tens* – 48 *tens* (20 groups of 24 equal 48 *tens*) to find a difference of 1 *ten*. We can combine this 1 *ten* with the 6 *ones* remaining in 496. We now have 16 *ones* remaining from our original dividend of 496, this is not enough to make a group of 24. We have a remainder of 16. The quotient is represented as $20\frac{16}{24}$ because we have 20 full groups of 24 in 496 and the remainder of 16 represents $\frac{16}{24}$ of another group. Our quotient of $20\frac{16}{24}$ is close to our estimate of 20, this helps us determine that our answer is reasonable.”

$$\begin{array}{r}
 \overline{) 496} \\
 \underline{- 48} \quad 20 \\
 16 \\
 \underline{- 0} \\
 16
 \end{array}$$

- For example, students use an algorithm to solve $94 \div 13$ and explain their thinking using base ten blocks and place value understanding. Instruction includes stating, “In this problem we are finding how many groups of 13 are in 94. We will begin by dividing our largest place value first. How many groups of 13 are in 9 tens? Recognizing that the 9 represents 90, if you divide 90 by 13 the result will be less than 10, so the quotient won’t have any whole tens. Remember that 94 is the same as 9 tens 4 ones and 94 ones, so we will see how many groups of 13 are in 94 ones. We can also think of this as $__ \times 13 = 94$. There are 7 groups of 13 in 94 ones. Next, we will subtract to find our remainder of 3. Our quotient is represented as $7 \frac{3}{13}$ because we have 7 full groups of 13 in 94 and the remainder of 3 represents $\frac{3}{13}$ of another group. Our quotient of $7 \frac{3}{13}$ is close to our estimate of 9, this helps us determine that our answer is reasonable.”

$$\begin{array}{r}
 7 \\
 13 \overline{) 94} \\
 \underline{- 91} \\
 3
 \end{array}$$

$94 \div 13 = 7 \frac{3}{13}$

- Instruction includes the use of place value columns to support place value understanding when using a division algorithm.
 - Example:

$$\begin{array}{r|l}
 & 7 \\
 13 \overline{) 94} & \\
 \underline{- 91} & \\
 \hline
 & 3
 \end{array}$$

$$\begin{array}{r|ll}
 & 2 & 0 \\
 24 \overline{) 496} & & \\
 \underline{- 48} & & \\
 \hline
 & 1 & 6 \\
 & \underline{-} & 0 \\
 \hline
 & & 16
 \end{array}$$

Instructional Tasks

Instructional Task 1 (MTR.7.1)

The Magnolia Outreach organization is donating 6,924 pounds rice to families in need. They pour all the rice into 15-pound containers.

Part A. How many containers will they fill if they use all the rice?

Part B. Will Magnolia Outreach be able to fill all the containers completely? If not, will the partially filled container be more or less than half-full? Explain how you know.

Instructional Items

Instructional Item 1

What is the quotient of $498 \div 72$?

**The strategies, tasks and items included in the BIG-M are examples and should not be considered comprehensive.*

MA.5.NSO.2.3

Benchmark

MA.5.NSO.2.3 Add and subtract multi-digit numbers with decimals to the thousandths, including using a standard algorithm with procedural fluency.

Connecting Benchmarks/Horizontal Alignment

- MA.5.NSO.1.5
- MA.5.AR.2.1, MA.5.AR.2.2, MA.5.AR.2.3
- MA.5.M.2.1
- MA.5.GR.2.1

Terms from the K-12 Glossary

- Equation
- Expression

Vertical Alignment

Previous Benchmarks

- MA.4.NSO.2.6, MA.4.NSO.2.7

Next Benchmarks

- MA.6.NSO.2.3

Purpose and Instructional Strategies

The purpose of this benchmark is for students to add and subtract multi-digit numbers with decimals to the thousandths with procedural fluency. In grade 4 (MA.4.NSO.2.7), students explored the addition and subtraction of multi-digit numbers with decimals to hundredths using money and manipulatives. In grade 6, students add and subtract positive fractions with procedural fluency.

- To demonstrate procedural fluency, students may choose a standard algorithm that works best for them and demonstrates their procedural fluency. A standard algorithm is a method that is efficient and accurate (*MTR.3.1*).
- When students use a standard algorithm, they should be able to justify why it works conceptually. Teachers can expect students to demonstrate how their algorithm works, for example, by comparing it to another method for addition and subtraction (*MTR.6.1*).
- Along with using a standard algorithm, students should estimate reasonable solutions before solving. Estimation helps students anticipate possible answers and evaluate whether their solutions make sense after solving.

Common Misconceptions or Errors

- Students can make computational errors while using standard algorithms when they cannot reason why their algorithms work. In addition, they can struggle to determine where or why that computational mistake occurred because they did not estimate reasonable values for intermediate outcomes as well as for the final outcome. During instruction, teachers should expect students to justify their work while using their chosen algorithms and engage in error analysis activities to connect their understanding to the algorithm.

Strategies to Support Tiered Instruction

- Instruction includes estimating reasonable values for sums and differences when adding and subtracting decimals to the hundredths.
 - For example, students make reasonable estimates for the sum of $6.32 + 2.84$. Instruction includes stating, “Before using an algorithm, we will estimate the sum to make sure that we are using the algorithm correctly and our answer is reasonable. I will use my understanding of rounding decimals to estimate my sum. The addend of 6.32 rounds to 6 when rounded to the nearest whole number and

the addend 2.84 rounds to 3 when rounded to the nearest whole number. A reasonable estimate for my sum would be 9 because $6 + 3 = 9$.”

- For example, students make reasonable estimates for the difference of $7.9 - 4.25$. Instruction includes stating, “Before using an algorithm, we will estimate the difference to make sure that we are using the algorithm correctly and our answer is reasonable. I will use my understanding of rounding decimals to estimate my difference. The minuend of 7.9 rounds to 8 when rounded to the nearest whole number and the subtrahend 4.25 rounds to 4 when rounded to the nearest whole number. A reasonable estimate for my difference would be 4 because $8 - 4 = 4$.”
- Instruction includes explaining and justifying mathematical reasoning while using an algorithm to add and subtract decimals to the hundredths. Instruction also includes determining if an algorithm was used correctly by analyzing any errors made and reviewing the reasonableness of solutions.
 - For example, students use a standard algorithm to determine $6.32 + 2.84$ and explain their thinking using a place value understanding. Instruction includes stating, “Begin by lining up the decimal points and place values for each addend. Next, add in hundredths place. *2 hundredths plus 4 hundredths are 6 hundredths*. Because the total number of *hundredths* is less than *10 hundredths* it is not necessary to regroup. Next, add in the tenths place. *3 tenths plus 8 tenths are 11 tenths*. Because I have more than *10 tenths* it is necessary to regroup the *10 tenths* to make one whole. After composing a group of *10 tenths* there is *1 tenth* remaining. Finally, add *6 ones* plus *2 ones* and the *1* whole that was regrouped from the tenths place. The sum is 9.16. Our sum of 9.16 is close to our estimate of 9, this helps us determine that our answer is reasonable.”

$$\begin{array}{r}
 \textcircled{1} \\
 6 \quad . \quad 3 \quad 2 \\
 + 2 \quad . \quad 8 \quad 4 \\
 \hline
 9 \quad . \quad 1 \quad 6
 \end{array}$$

- For example, students use a standard algorithm to determine $7.9 - 4.25$ and explain their thinking using place value understanding. The teacher reminds students that 7.9 is equivalent to 7.90 and uses a decimal grid to show the equivalency of 0.9 and 0.90 if needed. Instruction includes stating, “Begin by lining up the decimal points and place values. Next, subtract 4.25 starting in the *hundredths* place. There are not enough *hundredths* to subtract *5 hundredths* from *0 hundredths*. It is necessary to decompose one tenth into *10 hundredths*. Now there are *10 hundredths*, and there is enough to subtract *5 hundredths*. $10 \text{ hundredths} - 5 \text{ hundredths} = 5 \text{ hundredths}$. Then, subtract the *tenths*: $8 \text{ tenths} - 2 \text{ tenths} = 6 \text{ tenths}$. Finally, subtract the *ones*: $7 \text{ ones} - 4 \text{ ones} = 3 \text{ ones}$. The difference is 3.65. Our difference of 3.65 is close to our estimate of 4, this helps us determine that our answer is reasonable.”

$$\begin{array}{r}
 \quad \quad \textcircled{8} \quad \boxed{10} \\
 7 \quad . \quad 9 \quad 0 \\
 - 4 \quad . \quad 2 \quad 5 \\
 \hline
 3 \quad . \quad 6 \quad 5
 \end{array}$$

- For example, students use a standard algorithm to determine $1.9 + 2.3$ and explain their thinking using a place value understanding. Instruction includes stating, “Begin by lining up the decimal points and place values for each addend. Next, add in *tenths* place. *9 tenths plus 3 tenths are 12 tenths*. Because I have more than *10 tenths* it is necessary to regroup the *10 tenths* to make one whole. After composing a group of *10 tenths* there are *2 tenths* remaining. Finally, add *1 one plus 2 ones* and the *1 whole* that was regrouped from the *tenths* place. The sum is *4.2*. Our sum of *4.2* is close to our estimate of *4*, this helps us determine that our answer is reasonable.”

$$\begin{array}{r}
 \textcircled{1} \\
 1 \ . \ 9 \\
 + 2 \ . \ 3 \\
 \hline
 4 \ . \ 2
 \end{array}$$

- For example, students use a standard algorithm to determine $5.2 - 3.8$ and explain their thinking using place value disks and their understanding of place value. Instruction includes stating, “Begin by lining up the decimal points and place values. Next, subtract *3.8* starting in the *tenths* place. There are not enough *tenths* to subtract *8 tenths* from *2 tenths*. It is necessary to decompose one whole into *10 tenths*. Now there are a total of *12 tenths*, and there are enough to subtract *8 tenths*. $12 \text{ tenths} - 8 \text{ tenths} = 4 \text{ tenths}$. Finally, subtract the *ones*: $4 \text{ ones} - 3 \text{ ones} = 1 \text{ one}$. The difference is *1.4*. Our difference of *1.4* is close to our estimate of *1*, this helps us determine that our answer is reasonable.”

$$\begin{array}{r}
 4 \ . \ 2 \\
 - 3 \ . \ 8 \\
 \hline
 1 \ . \ 4
 \end{array}$$

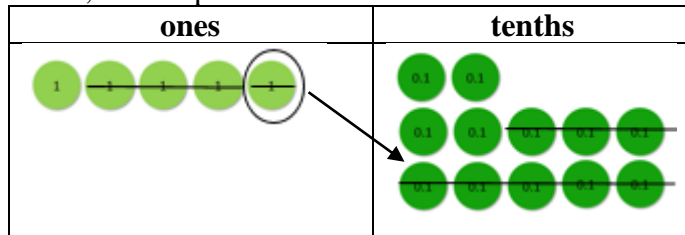

- Instruction includes the use of place value columns to support place value understanding when using an algorithm to add and subtract decimals.

Instructional Tasks

Instructional Task 1 (MTR.3.1)

Use a standard algorithm to find the difference of *eight hundred two and forty – six thousandths* and *three hundred and nine tenths*. Explain how you use your algorithm to subtract.

Instructional Items

Instructional Item 1

Find the sum and difference of 8.72 and 3.032.

**The strategies, tasks and items included in the BIG-M are examples and should not be considered comprehensive.*

MA.5.NSO.2.4

Benchmark

MA.5.NSO.2.4 Explore the multiplication and division of multi-digit numbers with decimals to the hundredths using estimation, rounding and place value.

Example: The quotient of 23 and 0.42 can be estimated as a little bigger than 46 because 0.42 is less than one-half and 23 times 2 is 46.

Benchmark Clarifications:

Clarification 1: Estimating quotients builds the foundation for division using a standard algorithm.

Clarification 2: Instruction includes the use of models based on place value and the properties of operations.

Connecting Benchmarks/Horizontal Alignment

- MA.5.NSO.1
- MA.5.FR.2.3
- MA.5.AR.2.2, MA.5.AR.2.3
- MA.5.M.1.1
- MA.5.M.2.1
- MA.5.GR.2.1

Terms from the K-12 Glossary

- Equation
- Expression

Vertical Alignment

Previous Benchmarks

- MA.4.NSO.2.7

Next Benchmarks

- MA.6.NSO.2.1

Purpose and Instructional Strategies

The purpose of this benchmark is for students to explore multiplication and division of multi-digit numbers with decimals using estimation, rounding, place value, and exploring the relationship between multiplication and division. This benchmark connects to the work students did in grade 4 with addition and subtraction of decimals (MA.4.NSO.2.7). Students achieve procedural fluency with multiplying and dividing multi-digit numbers with decimals in grade 6 (MA.6.NSO.2.1)

- Instruction of this benchmark focuses on number sense to help students develop procedural reliability while multiplying and dividing multi-digit numbers with decimals.
- During instruction, students should explore how the products and quotients of whole numbers relate to decimals.
 - For example, if students know the product of 8×7 and the quotient of $56 \div 4$,

then they can reason through 0.08×7 or $5.6 \div 0.4$ through place value relationships. Classroom discussions should allow students to explore these patterns and use them to estimate products and quotients (*MTR.4.1, MTR.6.1*).

- Teachers should connect what students know about place value and fractions.
 - For example, because students know that multiplying a number by one-fourth will result in a product that is smaller, multiplying a number by 0.25 (its decimal equivalence) will also result in a smaller product. In division, dividing a number by one-fourth and 0.25 will result in a larger quotient. Continued work in this benchmark will help students to generalize patterns in multiplication and division of whole numbers and fractions (*MTR.5.1*).
- Models that help students explore the multiplication and division of multi-digit numbers with decimals include base ten representations (e.g., blocks) and place value mats.

Common Misconceptions or Errors

- Students may not understand the reasoning behind the placement of the decimal point in the product. Modeling and exploring the relationships between place value will help students gain understanding.
- Students can confuse that multiplication always results in a larger product, and that division always results in a smaller quotient. Through classroom discussion, estimation and modeling, classroom work should address this misconception.

Strategies to Support Tiered Instruction

- Instruction includes opportunities to explore place value of decimals with concrete models and objects.
 - For example, students use place value understanding and a place value chart to compare 0.14 and 0.2. The teacher explains that when comparing decimals, we start with the digit to the far left because we want to compare the greatest place values first. Both values have a 0 in the ones place, so we will move to the *tenths* place. One-tenth is less than two-tenths, so $0.14 < 0.2$.

tens	ones	●	tenths	hundredths
	0		1	4
	0		2	

- For example, students compare 0.3 and 0.03 using decimal grids and represent each value and explain that 0.3 covers a greater are of the decimal grid than 0.03, so 0.3 is greater than 0.03.

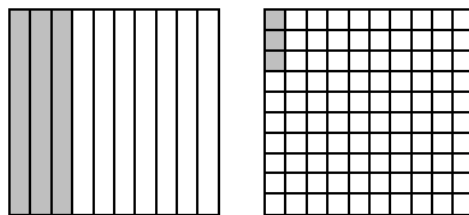

- Instruction includes opportunities to predict and explain the relative size of the product of two decimals. Students use models to check their prediction and solve. The teacher guides students to connect that multiplying a given number by a number less than one will result in a smaller number, and that multiplying a given number by a number greater than one will result in a larger number.
 - For example, students solve the following problem 0.2×0.5 . Students should reason about the size of the decimals and connect it back to their fraction

understanding and think about the multiplication sign signaling “groups of.” This expression could be interpreted as 0.2 “of” 0.5. This will help with the misconception of multiplying equals a larger product.

The picture below illustrates the product of 0.2 and 0.5. If the entire square is 1 unit, the gray region represents 0.5 units, and the red region represents 0.2 units. The overlap in purple contains 10 small squares, each of which represents 0.01 units. Therefore, the overlap portion contains $10 \times 0.01 = 0.10$ units. The overlap portions show a 0.2 by 0.5 rectangle, so the number of units it contains is the product 0.2 and 0.5.

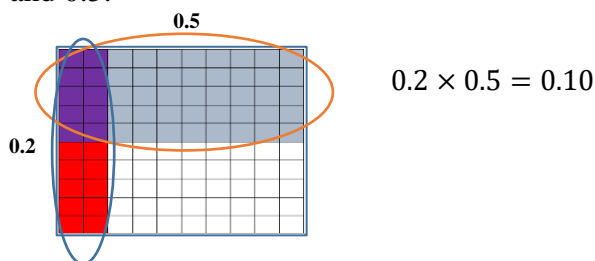

Instructional Tasks

Instructional Task 1 (MTR.4.1)

What is the same about the products of these expressions? What is different? Explain.

$$14 \times 5$$

$$0.14 \times 0.05$$

Instructional Task 2 (MTR.4.1)

What is the same about the quotients of these expressions? What is different? Explain.

$$50 \div 25$$

$$50 \div 0.25$$

Instructional Task 3 (MTR.5.1)

How can you use $2 \times 12 = 24$ to help you find the product of 2×1.2 ? Explain.

Instructional Items

Instructional Item 1

Raul reasons that the product of 82×0.56 will be greater than 41 and less than 82. Explain whether or not his conclusion is reasonable.

**The strategies, tasks and items included in the BIG-M are examples and should not be considered comprehensive.*

Benchmark

MA.5.NSO.2.5 Multiply and divide a multi-digit number with decimals to the tenths by one-tenth and one-hundredth with procedural reliability.

Example: The number 12.3 divided by 0.01 can be thought of as $12.3 \div 0.01 = 12.3 \times 100 = 1,230$ to determine the quotient is 1,230.

Benchmark Clarifications:

Clarification 1: Instruction focuses on the place value of the digit when multiplying or dividing.

Connecting Benchmarks/Horizontal Alignment

- MA.5.NSO.1.1, MA.5.NSO.1.2, MA.5.NSO.1.3, MA.5.NSO.1.4
- MA.5.FR.2.3
- MA.5.AR.2.2, MA.5.AR.2.3
- MA.5.M.1.1
- MA.5.M.2.1
- MA.5.GR.2.1

Terms from the K-12 Glossary

- Equation
- Expression

Vertical Alignment

Previous Benchmarks

- MA.4.NSO.2.6

Next Benchmarks

- MA.6.NSO.2.1

Purpose and Instructional Strategies

The purpose of this benchmark is for students to multiply multi-digit numbers with decimals to the tenths by .1 and by .01 with procedural reliability. Procedural reliability refers to the ability for students to develop an accurate, reliable method that aligns with a student’s understanding and learning style. Fluency of multiplying and dividing multi-digit whole numbers with decimals is not expected until grade 6 (MA.6.NSO.2.1).

- When multiplying and dividing, students should continue to use the number sense strategies built in MA.5.NSO.2.4 (estimation, rounding and exploring place value relationships). Using these strategies will help students predict reasonable solutions and determine whether their solutions make sense after solving.
- During instruction, students should see the relationship between multiplying and dividing multi-digit numbers with decimals to multiplying and dividing by whole numbers. Students extend their understanding to generalize patterns that exist when multiplying or dividing by 10 or 100 (*MTR.5.1*).
- Instruction includes the language that the “digits shift” relative to the position of the decimal point as long as there is an accompanying explanation. An instructional strategy that helps students see this is by putting digits on sticky notes or cards and showing how the values shift (or the decimal point moves) when multiplying by a power of ten.
 - For example, a teacher could show one card with a 3 and another with a 5, and place them on the left and right of a decimal point on a blank place value chart. The teacher could then ask students to multiply by ten and shift both digits one place left to show the equation $3.5 \times 10 = 35$. They could ask students to multiply by $\frac{1}{10}$ and show that $3.5 \times \frac{1}{10} = 0.35$. Instruction also includes using the language “moving the decimal point” as long as there is an explanation about

what happens to a number when multiplying and dividing by 0.1 and 0.01. Moving the decimal point does not change its meaning; it always indicates the transition from the ones to the tenths place. From either point of view, when the change is made it is important to emphasize the digits have new place values (*MTR.2.1, MTR.4.1, MTR.5.1*).

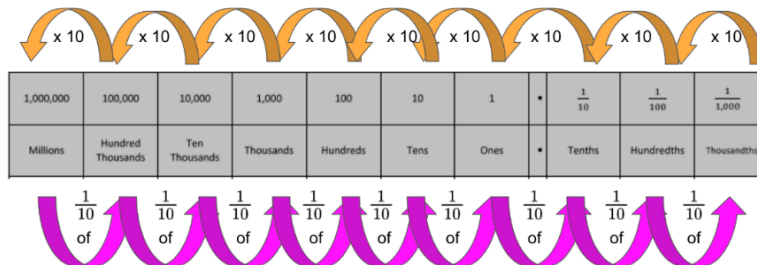

Common Misconceptions or Errors

- Students can confuse that multiplication always results in a larger product, and that division always results in a smaller quotient. Through classroom discussion, estimation and modeling, classroom work should address this misconception.

Strategies to Support Tiered Instruction





- Instruction includes the use of a place value chart to demonstrate how the value of a digit changes if the digit moves one place to the left or right. Instruction includes using place value understanding to make the connections between $\frac{1}{10}$ of, ten times less and dividing by 10. Also, the place value chart can be used to demonstrate that the decimal point marks the transition between the ones place and the tenths place.
 - For example, students multiply 4 by 10, then record 4 and the product of 40 in a place value chart. This process is repeated by multiplying 40 by 10. The teacher asks students to explain what happens to the digit 4 each time it is multiplied by 10. Next, the teacher explains that multiplying by $\frac{1}{10}$ is the same as dividing by 10. Students multiply 400 by $\frac{1}{10}$ and record the product in their place value chart. The process is repeated, multiplying 40 and 4 by $\frac{1}{10}$. Students explain how the value of the 4 changed when being multiplied by 10 and $\frac{1}{10}$.

hundreds	tens	ones	tenths	hundredths	thousandths
		4			
		$\times 10$			
	4	0			
	$\times 10$				
4	0	0			
	$\times \frac{1}{10}$				
	4	0			
		$\times \frac{1}{10}$			
		4			
			$\times \frac{1}{10}$		
			4		

- Instruction includes opportunities to use models such as place value disks to demonstrate how the value of a digit changes if the digit moves one place to the left or right. A place value chart can be used with the models to support place value understanding and demonstrate that the decimal point marks the transition between the ones place and the

tenths place. Instruction includes using place value understanding to make connections between $\frac{1}{10}$ of, ten times less and dividing by 10.

- For example, the teacher uses a familiar context such as money, asking students to explain the value of each digit in \$33.33. Then, students represent 33.33 in a place value chart using place value disks. Students compare the value of the whole numbers, (3 dollars and 30 dollars), then move to comparing 0.3 and 0.03 (30 cents and 3 cents). The teacher asks, “How does the value of the three in the hundredths place compare to the value of the three in the tenths place?” and explains that the three in the hundredths place is $\frac{1}{10}$ the value of the three in the tenths place and that multiplying by $\frac{1}{10}$ is the same as dividing by 10.

Instructional Tasks

Instructional Task 1 (MTR.7.1)

Part A. What is $\frac{1}{10}$ times 15?

Part B. How many dimes are in \$1.50?

Part C. Write an expression to represent how many dimes are in \$1.50.

Instructional Items

Instructional Item 1

Which compares the products of 7.8×0.1 and 7.8×10 correctly?

- The product of 7.8×0.1 is 100 times less than the product of 7.8×10 .
- The product of 7.8×0.1 is 10 times less than the product of 7.8×10 .
- The product of 7.8×0.1 is 100 times more than the product of 7.8×10 .
- The product of 7.8×0.1 is 10 times more than the product of 7.8×10 .

**The strategies, tasks and items included in the BIG-M are examples and should not be considered comprehensive.*

Fractions

MA.5.FR.1 Interpret a fraction as an answer to a division problem.

MA.5.FR.1.1

Benchmark

MA.5.FR.1.1 Given a mathematical or real-world problem, represent the division of two whole numbers as a fraction.

Example: At Shawn’s birthday party, a two-gallon container of lemonade is shared equally among 20 friends. Each friend will have $\frac{2}{20}$ of a gallon of lemonade which is equivalent to one-tenth of a gallon which is a little more than 12 ounces.

Benchmark Clarifications:

Clarification 1: Instruction includes making a connection between fractions and division by understanding that fractions can also represent division of a numerator by a denominator.

Clarification 2: Within this benchmark, the expectation is not to simplify or use lowest terms.

Clarification 3: Fractions can include fractions greater than one.

Connecting Benchmarks/Horizontal Alignment

Terms from the K-12 Glossary

- MA.5.NSO.2.2
- MA.5.AR.1.1
- MA.5.GR.3.3
- MA.5.DP.1.2

Vertical Alignment

Previous Benchmarks

- MA.4.NSO.2.4

Next Benchmarks

- MA.6.NSO.2.2

Purpose and Instructional Strategies

The purpose of this benchmark is for students to understand that a division expression can be written as a fraction by explaining their thinking when working with fractions in various contexts. This builds on the understanding developed in grade 4 that remainders are fractions (MA.4.NSO.2.4), and prepares students for the division of fractions in grade 6 (MA.6.NSO.2.2).

- When students read $\frac{5}{8}$ as “*five – eighths*,” they should be taught that $\frac{5}{8}$ can also be interpreted as “5 divided by 8,” where 5 represents the numerator and 8 represents the denominator of the fraction ($\frac{5}{8} = 5 \div 8$) and refers to 5 wholes divided into 8 equal parts.
- Teachers can activate students’ prior knowledge of fractions as division by using fractions that represent whole numbers (e.g., $\frac{24}{6}$). Familiar division expressions help build students’ understanding of the relationship between fractions and division (*MTR.5.1*).
- During instruction, provide examples accompanied by area and number line models.
- When solving mathematical or real-world problems involving division of whole numbers and interpreting the quotient in the context of the problem, students will be able to represent the division of two whole numbers as a mixed number, where the remainder is the fractional part’s numerator and the size of a group is its denominator (for example, $17 \div 3$ equals $5\frac{2}{3}$ which is the number of size 3 groups you can make from 17 objects

including the fractional group). Students should demonstrate their understanding by explaining or illustrating solutions using visual fraction models or equations.

Common Misconceptions or Errors

- Students can believe that the fraction bar represents subtraction in lieu of understanding that the fraction bar represents division.
- Students can have the misconception that division always result in a smaller number.
- Students can presume that dividends must always be greater than divisors and, thus, reorder when representing a division expression as a fraction. Show students examples of fractions with greater numerators and greater denominators to create a division equation.

Strategies to Support Tiered Instruction

- Instruction includes making the connection to models and tools previously used to understand division as equal groups or sharing, but now as a fraction in a real-world context.
 - For example, “Eight friends share four brownies” can be represented as $\frac{4}{8}$. This means that $4 \div 8$ can be represented using the model below. Four is divided into 8 equal parts, each part is $\frac{1}{2}$ of the brownie.



- Connecting the real-world application to the fraction will help students understand that the fraction really means division.
- Instruction includes making the connection to models and tools previously used to understand division as equal groups or sharing, but now as a fraction in a real-world context.
 - For example, “Marcos has 8 toy cars that he wants to put into 4 boxes equally. How many cars can go in each box?” $8 \div 4$ can be shown using a model of 8 wholes divided into 4 groups. The quotient would be the total number of pieces in each group. The model below would show that $8 \div 4 = 2$. This can also be expressed as $\frac{8}{4} = 2$.



- Instruction includes examples of fractions with greater numerators and greater denominators to create a division equation.

Instructional Tasks

Instructional Task 1 (MTR.7.1)

Create a real-world division problem that results in an answer equivalent to $\frac{3}{10}$.

Instructional Task 2 (MTR.3.1)

Write a mixed number that is equivalent to $10 \div 3$.

Instructional Task 3 (MTR.7.1)

Monica has a ribbon that is 8 feet long. She wants to make 12 bows for her friends. How long will each piece of the ribbon be? Express your answer in both feet and inches.

Instructional Task 4 (MTR.7.1)

Albert baked 18 fudge brownies for his video game club members. He wants to share the brownies with the 5 club members. How many brownies will each club member get?

Instructional Items

Instructional Item 1

Which expression is equivalent to $\frac{7}{12}$?

- a. $7 - 12$
- b. $7 \div 12$
- c. $12 - 7$
- d. $12 \div 7$

Instructional Item 2

Amanda has 12 pepperoni slices that need to be distributed equally among 5 mini pizzas. How many pepperoni slices will go on each mini pizza?

- a. $\frac{5}{12}$
- b. $2\frac{2}{5}$
- c. 7
- d. 60

**The strategies, tasks and items included in the BIG-M are examples and should not be considered comprehensive.*

MA.5.FR.2 Perform operations with fractions.

MA.5.FR.2.1

Benchmark

MA.5.FR.2.1 Add and subtract fractions with unlike denominators, including mixed numbers and fractions greater than 1, with procedural reliability.

Example: The sum of $\frac{1}{12}$ and $\frac{1}{24}$ can be determined as $\frac{1}{8}$, $\frac{3}{24}$, $\frac{6}{48}$ or $\frac{36}{288}$ by using different common denominators or equivalent fractions.

Benchmark Clarifications:

Clarification 1: Instruction includes the use of estimation, manipulatives, drawings or the properties of operations.

Clarification 2: Instruction builds on the understanding from previous grades of factors up to 12 and their multiples.

Connecting Benchmarks/Horizontal Alignment

- MA.5.NSO.2.3
- MA.5.AR.1.2
- MA.5.GR.2.1

Terms from the K-12 Glossary

Vertical Alignment

Previous Benchmarks

- MA.4.FR.1.3
- MA.4.FR.2.1/2.2

Next Benchmarks

- MA.6.NSO.2.3

Purpose and Instructional Strategies

The purpose of this benchmark is for students to understand that when adding or subtracting fractions with unlike denominators, equivalent fractions are generated to rewrite the fractions with like denominators, with which students have experience from grade 4 (MA.4.FR.2.2).

Procedural fluency will be achieved in grade 6 (MA.6.NSO.2.3).

- During instruction, have students begin with expressions with two fractions that require the rewriting of one of the fractions (where one denominator is a multiple of the other, like $1\frac{1}{2} + 3\frac{1}{6}$ or $\frac{3}{4} + \frac{5}{8}$) and progress to expressions where both fractions must be rewritten (where denominators are not multiples of one another, like $\frac{4}{5} + \frac{2}{3}$ or $1\frac{1}{2} + 9\frac{2}{3}$). In doing so, students can explore how both fractions need like denominators to make addition and subtraction easier. Once students have stronger conceptual understanding, expressions requiring adding or subtracting 3 or more numbers should be included in instruction.
- It is important for students to practice problems that include various fraction models as students may find that a circular model might not be the best model when adding or subtracting fractions because of the difficulty in partitioning the pieces so they are equal (*MTR.2.1*).
- When students use an algorithm to add or subtract fractions, encourage students' use of flexible strategies.
 - For example, students can use a partial sums strategy when adding $1\frac{2}{3} + 4\frac{4}{5}$ by adding the whole numbers $1 + 4$ together first before adding the fractional parts

and regrouping when necessary.

- Mental computations and estimation strategies should be used to determine the reasonableness of solutions.
 - For example, when adding $1\frac{2}{3} + 4\frac{4}{5}$, students could reason that the sum will be greater than 6 because the sum of the whole numbers is 5 and the sum of the fractional parts in the mixed numbers will be greater than 1. Keep in mind that estimation is about getting reasonable solutions and not about getting exact solutions, therefore allow for flexible estimation strategies and expect students to justify them.
- Although not required, instruction may include students using equivalent fractions to simplify answers.

Common Misconceptions or Errors

- Students can carry misconceptions from grade 4 about adding and subtracting fractions and understanding why the denominator remains the same. Emphasize the use of area and number line models, and present expressions in numeral-word form to help understand that the denominator is the unit.
 - For example, “5 *eighths* + 9 *eighths* is equal to how many *eighths*?”
- Students often try to use different models when adding, subtracting or comparing fractions.
 - For example, they may use a circle for thirds and a rectangle for fourths, when comparing fractions with thirds and fourths.
- Remind students that the representations need to be from the same whole models with the same shape and same size. In a real-world problem, this often looks like same units.
 - For example, “Trey has $1\frac{3}{4}$ cups of water and Rachel has $2\frac{5}{6}$ cups of water. How many cups of water do they have?”

Strategies to Support Tiered Instruction

- Instruction includes concrete models and drawings that help solidify understanding that when adding and subtracting with unlike denominators, the value of the fractional parts remains the same.
 - For example, students create a model for each of the fractions in the problem $\frac{2}{3} - \frac{1}{4}$.

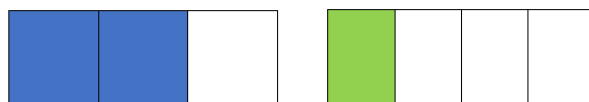

It is important for students to draw these two models the same size. Once the models are created, students will then need to be able to make the all the pieces within each model the same size to be able to subtract. They then divide each piece of the $\frac{2}{3}$ model into fourths. They then divide each piece of the $\frac{1}{4}$ model into thirds. Now both models are divided in to 12 pieces and the subtraction problem can be represented as $\frac{8}{12} - \frac{3}{12}$. It is important to note that the area of the models did not change. Just because the fraction changed, the value of the fraction did not change.



Now, students can subtract the same size pieces. So $\frac{2}{3} - \frac{1}{4} = \frac{5}{12}$.



- Instruction includes concrete models and drawings that help solidify understanding that when adding and subtracting with unlike denominators, students are adding and subtracting pieces of the whole.
 - For example, the teacher emphasizes the use of area and number line models and presents expressions in numeral-word form to help understand that one over the denominator is the unit.
 - For example, “3 *twelfths* + 6 *twelfths* are equal to how many *twelfths*?” The denominator is 12 so one unit is equal to 1 *twelfth*.

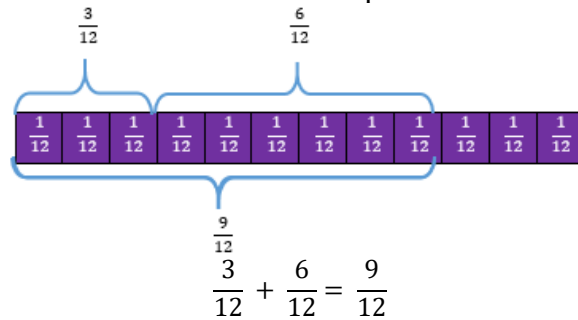

Instructional Tasks

Instructional Task 1 (MTR.2.1)

Write an expression for the visual model below. Then find the sum.

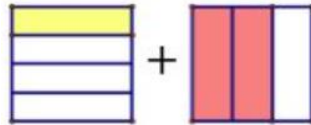

Instructional Task 2 (MTR.2.1)

Use a visual fraction model to find the value of the expression $\frac{3}{5} + \frac{4}{15}$.

Instructional Task 3 (MTR.3.1)

Find the value of the expression $3\frac{5}{6} + \frac{3}{8}$.

Instructional Task 4 (MTR.3.1)

Find the differences $\frac{5}{7} - \frac{2}{3}$ and $2\frac{1}{4} - \frac{4}{6}$.

Instructional Items

Instructional Item 1

Find the sum $\frac{5}{8} + \frac{7}{16}$.

- a. $1\frac{2}{16}$
- b. $\frac{12}{16}$
- c. $1\frac{1}{16}$
- d. $\frac{12}{24}$

Instructional Item 2

Find the difference $2\frac{1}{4} - \frac{3}{8}$.

- a. $1\frac{2}{4}$
- b. $1\frac{5}{8}$
- c. $1\frac{7}{8}$
- d. $2\frac{2}{8}$

**The strategies, tasks and items included in the BIG-M are examples and should not be considered comprehensive.*

MA.5.FR.2.2

Benchmark

MA.5.FR.2.2 Extend previous understanding of multiplication to multiply a fraction by a fraction, including mixed numbers and fractions greater than 1, with procedural reliability.

Benchmark Clarifications:

Clarification 1: Instruction includes the use of manipulatives, drawings or the properties of operations.

Clarification 2: Denominators limited to whole numbers up to 20.

Connecting Benchmarks/Horizontal Alignment

Terms from the K-12 Glossary

- MA.5.NSO.2.1, MA.5.NSO.2.4
- MA.5.AR.1.2
- MA.5.GR.2.1

Vertical Alignment

Previous Benchmarks

- MA.4.FR.2.4

Next Benchmarks

- MA.6.NSO.2.2

Purpose and Instructional Strategies

The purpose of this benchmark is for students to learn strategies to multiply two fractions. This continues the work from grade 4 where students multiplied a whole number times a fraction and a fraction times a whole number (MA.4.FR.2.4). Procedural fluency will be achieved in grade 6 (MA.6.NSO.2.2).

- During instruction, students are expected to multiply fractions including proper fractions, improper fractions (fractions greater than 1), and mixed numbers efficiently and accurately.
- Visual fraction models (area models, tape diagrams, number lines) should be used and created by students during their work with this benchmark (*MTR.2.1*). Visual fraction models should show how a fraction is partitioned into parts that are the same as the product of the denominators.

$$1\frac{1}{2} \times 1\frac{1}{3}$$

	1	+	$\frac{1}{3}$	
1	$1 \times 1 =$ 1	1	$1 \times \frac{1}{3}$ $= \frac{1}{3}$	
$\frac{1}{2}$	$1 \times \frac{1}{2} =$ $\frac{1}{2}$	$\frac{1}{2}$	$\frac{1}{2} \times \frac{1}{3}$ $= \frac{1}{6}$	$\frac{1}{2} \times \frac{1}{3}$

- When exploring an algorithm to multiply fractions ($\frac{a}{b} \times \frac{c}{d} = \frac{a \times c}{b \times d}$), make connections to an accompanying area model. This will help students understand the algorithm conceptually and use it more accurately.
- Instruction includes students using equivalent fractions to simplify answers; however, putting answers in simplest form is not a priority.

Common Misconceptions or Errors

- Students may believe that multiplication always results in a larger number. Using models when multiplying with fractions will enable students to generalize about multiplication algorithms that are based on conceptual understanding (*MTR.5.1*).
- Students can have difficulty with word problems when determining which operation to use, and the stress of working with fractions makes this happen more often.
 - For example, “Mark has $\frac{3}{4}$ yards of rope and he gives a third of the rope to a friend. How much rope does Mark have left?” expects students to first find $\frac{1}{3}$ of $\frac{3}{4}$, or multiply $\frac{1}{3} \times \frac{3}{4}$, and then to find the difference to find how much Mark has left. On the other hand, “Mark has $\frac{3}{4}$ yards of rope and gives $\frac{1}{3}$ yard of rope to a friend. How much rope does Mark have left?” only requires finding the difference $\frac{3}{4} - \frac{1}{3}$.

Strategies to Support Tiered Instruction

- Instruction involves real-world examples and models which allow students to see that multiplication does not always result in a larger number.
 - For example, the teacher provides the problem: “Tau has $\frac{1}{4}$ of the lasagna pan leftover from the party in the refrigerator. He eats one half of the leftovers for

dinner. How much of the lasagna did he eat for dinner?" This can be written as

$$\frac{1}{2} \times \frac{1}{4} \text{ or } \frac{1}{2} \text{ "of"} \frac{1}{4}$$

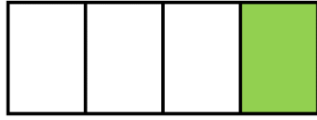

$\frac{1}{4}$ of the lasagna pan leftover in the refrigerator.

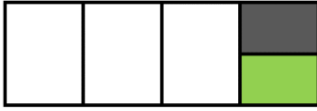

$\frac{1}{2}$ of the lasagna leftover in the refrigerator.

When students think about what is left in the refrigerator now, they must think in terms of the whole pan of lasagna. Tau didn't eat half the pan; he ate half of the portion that was left. So how much of the whole pan did he eat?

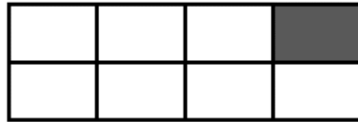

$\frac{1}{8}$ of the lasagna pan.

Instructional Tasks

Instructional Task 1 (MTR.4.1, MTR.7.1)

Part A. Maritza has $4\frac{1}{2}$ cups of cream cheese. She uses $\frac{3}{4}$ of the cream cheese for a banana pudding recipe. After she uses it for the recipe, how much cream cheese will Maritza have left?

Part B. To find out how much cream cheese she used, Maritza multiplied $4\frac{1}{2} \times \frac{3}{4}$ as $(4 \times \frac{3}{4}) + (\frac{1}{2} \times \frac{3}{4})$. Will this method work? Why or why not?

Part C. What additional step is required to find how much cream cheese she has left?

Instructional Items

Instructional Item 1

What is the product of $\frac{1}{5} \times 6\frac{1}{2}$?

- $\frac{6}{10}$
- $\frac{12}{5}$
- $6\frac{7}{10}$
- $1\frac{3}{10}$

*The strategies, tasks and items included in the BIG-M are examples and should not be considered comprehensive.

Benchmark

- MA.5.FR.2.3** When multiplying a given number by a fraction less than 1 or a fraction greater than 1, predict and explain the relative size of the product to the given number without calculating.

Benchmark Clarifications:

Clarification 1: Instruction focuses on the connection to decimals, estimation and assessing the reasonableness of an answer.

Connecting Benchmarks/Horizontal Alignment

- MA.5.NSO.2.4, MA.5.NSO.2.5
- MA.5.GR.2.1

Terms from the K-12 Glossary

Vertical Alignment

Previous Benchmarks

- MA.4.FR.2.4

Next Benchmarks

- MA.6.NSO.2.2, MA.6.NSO.2.3

Purpose and Instructional Strategies

The purpose of this benchmark is for students to examine how numbers change when multiplying by fractions (*MTR.2.1*). Students already had experience with this idea when they multiplied a fraction by a whole number in grade 4 (MA.4.FR.2.4). Work from this benchmark will help prepare students to multiply and divide fractions and decimals with procedural fluency in grade 6 (MA.6.NSO.2.2).

- It is important for students to have experiences examining:
 - when multiplying by a fraction greater than 1, the number increases;
 - when multiplying by a fraction equal to 1, the number stays the same; and
 - when multiplying by a fraction less the 1, the number decreases.
- Throughout instruction, encourage students to use models or drawings to assist them with a visual of the relative size. Models to consider when multiplying fractions to assist with finding relative size without calculating include, but are not limited to, area models (rectangles), linear models (fraction strips/bars and number lines) and set models (counters). Include examples with equivalent fractions and decimals (*MTR.2.1*).
- Have students explain how they used the model or drawing to arrive at the solution and justify reasonableness of their answers (*MTR.4.1*).

Common Misconceptions or Errors

- Students may believe that multiplication always results in a larger number. This is why it is imperative to include models during instruction when multiplying fractions so students can see and experience the results and begin to make generalizations that are based on their understanding. Ultimately, allowing students to begin to understand that multiplying by a fraction less than one will result in a lesser product, but when multiplying by a fraction greater than one will result in a greater product.

Strategies to Support Tiered Instruction

- Instruction includes opportunities to predict and explain the relative size of the product of a given number by a fraction less than one or a fraction greater than one. Students use models to check their prediction and solve. The teacher guides students to connect that

multiplying a given number by a fraction less than one will result in a smaller number and that multiplying a given number by a fraction greater than one will result in a larger number.

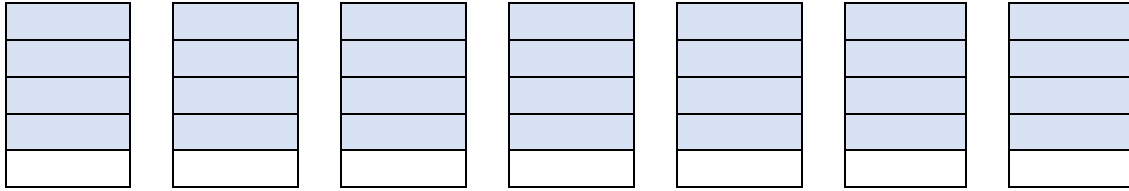

$$7 \times \frac{4}{5} = \frac{28}{5} = 5 \frac{3}{5}$$

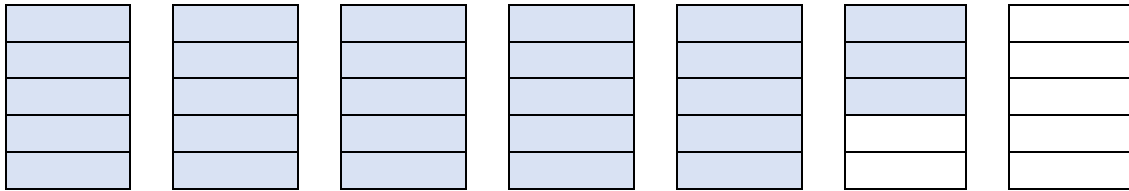

- For example, the teacher displays the problem $7 \times \frac{4}{5}$ and asks students to predict if the product will be greater than, equal to, or less than 7 (it will be less than 7). Students use a visual model to represent the problem to determine $7 \times \frac{4}{5} = \frac{28}{5}$. This is repeated with additional examples using fractions both greater than, equal to, and less than one.
- Instruction includes providing hands-on opportunities to predict and explain the relative size of the product of a given number by a fraction less than one or a fraction greater than one. Students use fraction strips/bars or counters to check their prediction and solve, connecting that multiplying a given number by a fraction less than one will result in a smaller number and that multiplying a given number by a fraction greater than one will result in a larger number.
 - For example, the teacher displays the problem $4 \times \frac{3}{8} = \underline{\quad}$. Then, the teacher asks students to predict if the product will be greater than, equal to, or less than 4 (it will be less than 4).
 - Using fraction bars or fraction strips, the teacher models solving this problem with explicit instruction and guided questioning. Students explain how to use fraction bars or fraction strips as a model to solve this problem. This is repeated with additional examples using fractions both greater than, equal to, and less than one.

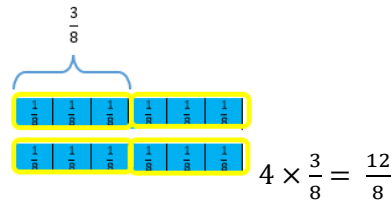

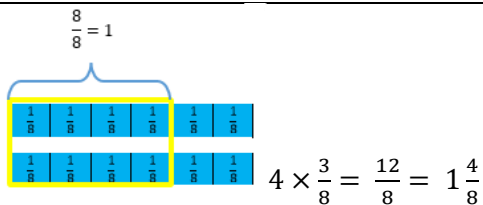

Instructional Tasks

Instructional Task 1 (MTR.7.1)

Derrick is playing a computer game where he must multiply a number by a factor that increases the number's size each time. Select all of the factors that he could multiply by to continue to increase the size of his number? Explain your thinking.

- $\frac{3}{4}$
- $\frac{4}{3}$
- $1 \frac{1}{9}$
- 1.01
- $\frac{5}{2}$
- $\frac{8}{9}$
- $\frac{99}{100}$
- $\frac{2}{2}$

Instructional Items

Instructional Item 1

Which of the following expressions will have a product greater than 4?

- $4 \times \frac{8}{8}$
- $\frac{3}{4} \times 4$
- $4 \times \frac{99}{100}$
- $\frac{101}{100} \times 4$

Instructional Item 2

Fill in the blank. The product of the expression $\frac{63}{65} \times 20$ will be _____ 20.

- less than
- equal to
- greater than
- half of

**The strategies, tasks and items included in the BIG-M are examples and should not be considered comprehensive.*

MA.5.FR.2.4

Benchmark

MA.5.FR.2.4 Extend previous understanding of division to explore the division of a unit fraction by a whole number and a whole number by a unit fraction.

Benchmark Clarifications:

Clarification 1: Instruction includes the use of manipulatives, drawings or the properties of operations.

Clarification 2: Refer to Situations Involving Operations with Numbers (Appendix A).

Connecting Benchmarks/Horizontal Alignment

- MA.5.NSO.2.2
- MA.5.AR.1.3

Terms from the K-12 Glossary

Vertical Alignment

Previous Benchmarks

- MA.4.FR.2.4

Next Benchmarks

- MA.6.NSO.2.2, MA.6.NSO.2.3

Purpose and Instructional Strategies

The purpose of this benchmark is for students to experience division with whole number divisors and unit fraction dividends (fractions with a numerator of 1) and with unit fraction divisors and whole number dividends. This work prepares for division of fractions in grade 6 (MA.6.NSO.2.2) in the same way that in grade 4 (MA.4.FR.2.4) students were prepared for multiplication of fractions.

- Instruction should include the use of manipulatives, area models, number lines, and emphasizing the properties of operations (e.g., through fact families) for students to see the relationship between multiplication and division (*MTR.2.1*).
- Throughout instruction, students should have practice with both types of division: a unit fraction that is divided by a non-zero whole number and a whole number that is divided by a unit fraction.
- Students should be exposed to all situation types for division (refer to Situations Involving Operations with Numbers (Appendix A)).
- The expectation of this benchmark is not for students to use an algorithm (e.g., multiplicative inverse) to divide by a fraction.
- Instruction includes students using equivalent fractions to simplify answers; however, putting answers in simplest form is not a priority.

Common Misconceptions or Errors

- Students may believe that division always results in a smaller number, which is true when dividing a fraction by a whole number, but not when dividing a whole number by a fraction. Using models will help students develop the understanding needed for computation with fractions.

Strategies to Support Tiered Instruction

- Instruction includes making the connection to models and tools previously used to understand division as equal groups or sharing. The teacher uses models to develop the understanding needed for computation with fractions.
 - For example, $8 \div \frac{1}{4}$ can be shown using a model of 8 wholes divided into parts of size $\frac{1}{4}$. The quotient would be the total number of $\frac{1}{4}$ pieces. The model below

would show that $8 \div \frac{1}{4} = 32$.



- For example, $\frac{1}{4} \div 8$ can be represented using the model below. One-fourth is divided into 8 equal parts, each part is $\frac{1}{32}$ of the whole.

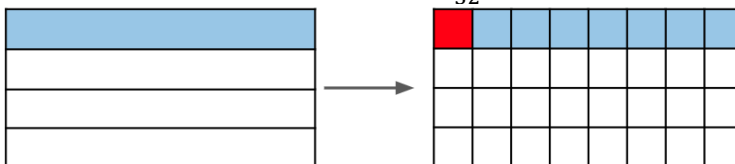

- Instruction includes real-world situations to interact with the content. The teacher provides students with a division expression with a real-world context and provides items to represent the situation to allow connections to be made.
 - For example, the teacher provides students with the following situation: “The teacher brought in 8 brownies to split between the class. She cut the brownies into pieces of size $\frac{1}{4}$ so there would be enough for the whole class. How many $\frac{1}{4}$ pieces will there be?” The teacher provides students with images of eight brownies (or models to represent them) and has them divide or cut them into $\frac{1}{4}$ pieces to determine how many pieces they will have (32 pieces).
 - For example, the teacher provides students with the following situation: “The teacher baked a pan of brownies. All but $\frac{1}{4}$ of the pan was eaten. She brought in the remaining $\frac{1}{4}$ and divided it into 8 equal pieces for her co-teachers. What fraction of the whole pan will each person get?” The teacher provides students with an image of a pan of brownies with $\frac{1}{4}$ left (or model to represent it). The students divide the $\frac{1}{4}$ portion into 8 equal pieces. The teacher then connects the remaining part of the brownies to the whole pan so that students can make the connection to the total number of the smaller pieces representing $\frac{1}{32}$ of the whole.

Instructional Tasks

Instructional Task 1 (MTR.5.1, MTR.7.1)

Part A. Emily has 2 feet of ribbon to make friendship bracelets. Use models and equations to answer the questions below.

- a. How many friendship bracelets can she make if each bracelet uses 2 feet of ribbon?
- b. How many friendship bracelets can she make if each bracelet uses 1 foot of ribbon?
- c. How many friendship bracelets can she make if each bracelet uses 1 half foot of ribbon?
- d. How many friendship bracelets can she make if each bracelet uses 1 third foot of ribbon?
- e. How many friendship bracelets can she make if each bracelet uses 1 fifth foot of ribbon?

Part B. Do you see any patterns in the models and equations you have written? Explain.

Instructional Items

Instructional Item 1

What is the quotient of $\frac{1}{3} \div 5$?

- a. $\frac{1}{15}$
- b. 15
- c. $\frac{5}{3}$
- d. $\frac{3}{5}$

Instructional Item 2

How many fourths are in 8 wholes?

- a. 4
- b. 8
- c. 16
- d. 32

**The strategies, tasks and items included in the BIG-M are examples and should not be considered comprehensive.*

Algebraic Reasoning

MA.5.AR.1 Solve problems involving the four operations with whole numbers and fractions.

MA.5.AR.1.1

Benchmark

MA.5.AR.1.1 Solve multi-step real-world problems involving any combination of the four operations with whole numbers, including problems in which remainders must be interpreted within the context.

Benchmark Clarifications:

Clarification 1: Depending on the context, the solution of a division problem with a remainder may be the whole number part of the quotient, the whole number part of the quotient with the remainder, the whole number part of the quotient plus 1, or the remainder.

Connecting Benchmarks/Horizontal Alignment

- MA.5.NSO.2.1, MA.5.NSO.2.2
- MA.5.FR.1.1
- MA.5.GR.3.3
- MA.5.GR.4.2
- MA.5.DP.1.2

Terms from the K-12 Glossary

- Dividend
- Divisor
- Equation

Vertical Alignment

Previous Benchmarks

- MA.3.AR.1.2
- MA.4.AR.1.1

Next Benchmarks

- MA.6.NSO.2.3

Purpose and Instructional Strategies

The purpose of this benchmark is for students to solve multistep word problems with whole numbers and whole-number answers involving any combination of the four operations. Work in this benchmark continues instruction from grade 4 where students interpreted remainders in division situations (MA.4.AR.1.1) (*MTR.7.1*), and prepares for solving multi-step word problems involving fractions and decimals in grade 6 (MA.6.NSO.2.3).

- To allow for an effective transition into algebraic concepts in grade 6 (MA.6.AR.1.1), it is important for students to have opportunities to connect mathematical statements and number sentences or equations.
- During instruction, teachers should allow students an opportunity to practice with word problems that require multiplication or division which can be solved by using drawings and equations, especially as the students are making sense of the context within the problem (*MTR.5.1*).
- Teachers should have students practice with representing an unknown number in a word problem with a variable by scaffolding from the use of only an unknown box.
- Offer word problems to students with the numbers covered up or replaced with symbols or icons and ensure to ask students to write the equation or the number sentence to show the problem type situation (*MTR.6.1*).

- Interpreting number pairs on a coordinate graph can provide students opportunities to solve multi-step real-world problems with the four operations (MA.5.GR.4.2).

Common Misconceptions or Errors

- Students may apply a procedure that results in remainders that are expressed as r for ALL situations, even for those in which the result does not make sense.
 - For example, when a student is asked to solve the following problem: “There are 34 students in a class bowling tournament. They plan to have 3 students in each bowling lane. How many bowling lanes will they need so that everyone can participate?” the student response is “11 r 1 bowling lanes,” without any further understanding of how many bowling lanes are needed and how the students may be divided among the last 1 or 2 lanes. To assist students with this misconception, pose the question “What does the quotient mean?”

Strategies to Support Tiered Instruction

- Instruction includes opportunities to engage in guided practice completing multi-step word problems with any combination of the four operations, including problems with remainders. Students use drawings and models to understand how to interpret the remainder in situations in which they will need to drop the remainder as their solution.
 - For example, the teacher displays and reads the following problem aloud: “There are 58 fourth grade students and 45 fifth grade students going on a class field trip. They plan to have 20 students in each van. How many vans will they need so that everyone can participate?” Students use models or drawings to represent the problem and write an equation to represent the problem. The teacher uses guided questioning to encourage students to identify that they will need to add one to the quotient as their solution. If students state that they will need $5r3$ vans, the teacher refers to the models to prompt students that a sixth van is needed for the remaining three students. If students state that they will need 3 more vans since the remainder is 3, the teacher reminds students through guided questioning that the remainder of 3 represents 3 remaining students and only 1 more van is needed (i.e., “add 1 to the quotient”). This is repeated with similar multistep real-world problems, asking students to explain what the quotient means in problems involving remainders.

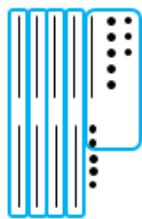

$$(58 + 45) \div 20 = v$$

$$103 \div 20 = 5r3$$

They will need 6 vans so everyone can participate on the trip.

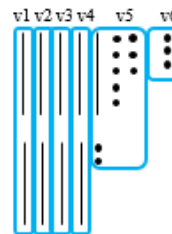

They will need 6 vans so everyone can participate on the trip.

$$v = \text{van}$$

- Instruction includes opportunities to engage in practice with explicit instruction completing multi-step word problems with any combination of the four operations, including problems with remainders. Students use manipulatives to understand how to interpret the remainder in situations in which they will need to drop the remainder as their solution.

- For example, the teacher displays and reads the following problem aloud: “There are 18 red markers and 26 black markers on the art table. Ms. Williams is cleaning up and can put 10 markers in each box. How many boxes will she need so all the markers will be put into box?” The teacher uses manipulatives (e.g., base ten blocks) to represent the problem, having students write an equation to represent the problem. The teacher uses guided questioning to encourage students to identify that they will need to add 1 to the quotient as their solution. If students state that she will need 4r4 boxes, the teacher refers to the models to prompt students that a fifth box is needed for the remaining four markers. If students state that they will need 4 more boxes since the remainder is 4, the teacher reminds students through guided questioning that the remainder of 4 represents 4 remaining markers and only 1 more box is needed (i.e., “add 1 to the quotient”). This is repeated with similar multistep real-world problems, asking students to explain what the quotient means in problems involving remainders.

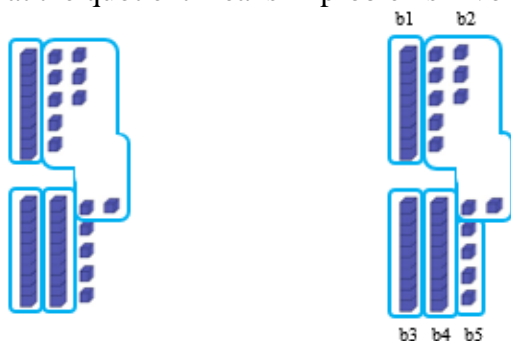

$$(18 + 26) \div 10 = b$$

$$44 \div 10 = 4r4$$

Ms. Williams will need 5 boxes.
 $b = \text{box}$

Instructional Tasks

Instructional Task 1 (MTR.6.1)

There are 128 girls in the Girl Scouts Troop 1653 and 154 girls in the Girl Scouts Troop 1764. Both Troops are going on a camping trip. Each bus can hold 36 girls. How many buses are needed to get all the girls to the camping site?

Instructional Items

Instructional Item 1

A shoe store orders 17 cases each containing 142 pairs of sneakers and 12 cases each containing 89 pairs of sandals. How many more pairs of sneakers did the store order?

**The strategies, tasks and items included in the BIG-M are examples and should not be considered comprehensive.*

MA.5.AR.1.2

Benchmark

MA.5.AR.1.2 Solve real-world problems involving the addition, subtraction or multiplication of fractions, including mixed numbers and fractions greater than 1.

Example: Shanice had a sleepover, and her mom is making French toast in the morning. If her mom had $2\frac{1}{4}$ loaves of bread and used $1\frac{1}{2}$ loaves for the French toast, how much bread does she have left?

Benchmark Clarifications:

Clarification 1: Instruction includes the use of visual models and equations to represent the problem.

Connecting Benchmarks/Horizontal Alignment

Terms from the K-12 Glossary

- MA.5.FR.2.1, MA.5.FR.2.2
- MA.5.M.1.1
- MA.5.GR.2.1
- MA.5.DP.1.1

Vertical Alignment

Previous Benchmarks

- MA.4.AR.1.2, MA.4.AR.1.3

Next Benchmarks

- MA.6.NSO.2.3

Purpose and Instructional Strategies

The purpose of this benchmark is to continue the work from grade 4 where students began solving real-world with fractions, and prepares them for grade 6 (MA.6.NSO.2.3) where they will solve real-world fraction problems using all four operations with fractions (*MTR.7.1*).

- Students need to develop an understanding that when adding or subtracting fractions, the fractions must refer to the same whole.
- During instruction, teachers should provide opportunities for students to practice solving problems using models or drawings to add, subtract or multiply with fractions. Begin with students modeling with whole numbers, have them explain how they used the model or drawing to arrive at the solution, then scaffold using the same methodology using fraction models.
- Models to consider when solving fraction problems should include, but are not limited to, area models (rectangles), linear models (fraction strips/bars and number lines) and set models (counters) (*MTR.2.1*).
- Please note that it is not expected for students to always find least common multiples or make fractions greater than 1 into mixed numbers, but it is expected that students know and understand equivalent fractions, including naming fractions greater than 1 as mixed numbers to add, subtract or multiply.
- It is important that teachers have students rename the fractions with a common denominator when solving addition and subtraction fraction problems in lieu of the “butterfly” method (or other shortcut/mnemonic) to ensure students build a complete conceptual understanding of what makes solving addition and subtraction of fractions problems true.

Common Misconceptions or Errors

- When solving real-world problems, students can often confuse contexts that require subtraction and multiplication of fractions.
 - For example, “Mark has $\frac{3}{4}$ yards of rope and he gives half of the rope to a friend. How much rope does Mark have left?” expects students to find $\frac{1}{2}$ of $\frac{3}{4}$, or multiply $\frac{1}{2} \times \frac{3}{4}$ to find the product that represents how much is given to the friend. On the other hand, “Mark has $\frac{3}{4}$ yards of rope and gives $\frac{1}{2}$ yard of rope to a friend. How much rope does Mark have left?” expects students to take $\frac{1}{2}$ yard from $\frac{3}{4}$ yard, or subtract $\frac{3}{4} - \frac{1}{2}$ to find the difference. Encourage students to look for the units in the problem (e.g., $\frac{1}{2}$ yard versus $\frac{1}{2}$ of the whole rope) to determine the appropriate operation.
- Students may believe that multiplication always results in a larger number. Using models when multiplying with fractions will enable students to generalize about multiplication algorithms that are based on conceptual understanding (*MTR.5.1*).
- Students can have difficulty with word problems when determining which operation to use, and the stress of working with fractions makes this happen more often.
 - For example, “Mark has $\frac{3}{4}$ yards of rope and he gives a third of the rope to a friend. How much rope does Mark have left?” expects students to first find $\frac{1}{3}$ of $\frac{3}{4}$, or multiply $\frac{1}{3} \times \frac{3}{4}$, and then to find the difference to find how much Mark has left. On the other hand, “Mark has $\frac{3}{4}$ yards of rope and gives $\frac{1}{3}$ yard of rope to a friend. How much rope does Mark have left?” only requires finding the difference $\frac{3}{4} - \frac{1}{3}$.

Strategies to Support Tiered Instruction

- Instruction includes opportunities to identify the appropriate operation to use in a real-world problem that requires addition, subtraction, or multiplication of fractions. The teacher guides students to identify the units in the problem for clarification on which operation is appropriate.
 - For example, the teacher displays and reads the following two problems:
 - “Ganie has $\frac{7}{8}$ of a bar of chocolate left and gives half of what she has to her friend Sarah. How much of a whole chocolate bar does she have left?”
 - “Ganie has $\frac{7}{8}$ of a bar of chocolate left and she gives $\frac{1}{2}$ of the original bar of chocolate to her friend Sarah. How much of her chocolate bar does she have left?” (See illustration below)

The teacher uses questioning and prompting to have students identify what operations must be used to solve each problem. The teacher asks students to share what they notice about each problem (e.g., the similarities and the differences), placing emphasis on the units (e.g., “half of the amount of chocolate that Janie has in the first problem vs. $\frac{1}{2}$ of the whole chocolate bar” in the second problem). The teacher guides students to identify that in the first problem, they will need to multiply $\frac{7}{8} \times \frac{1}{2}$ and in the second problem, they will need to subtract $\frac{7}{8} - \frac{1}{2}$ to solve. Students solve using models.

$$\frac{7}{8} \times \frac{1}{2} = \frac{7}{16}$$

$\frac{1}{8}$	$\frac{1}{8}$	$\frac{1}{8}$	$\frac{1}{8}$	$\frac{1}{8}$	$\frac{1}{8}$	$\frac{1}{8}$	$\frac{1}{8}$

$$\frac{7}{8} - \frac{1}{2} = \frac{7}{8} - \frac{4}{8} = \frac{3}{8}$$

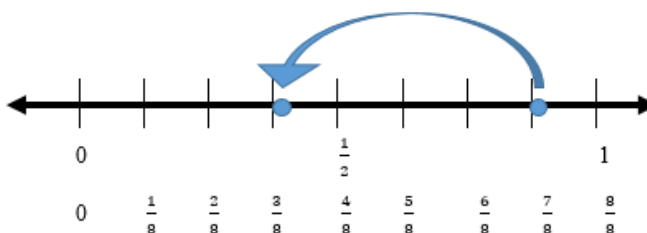

- For example, the teacher displays and reads the following problem: “Tia has $\frac{3}{8}$ yards of ribbon and she gives half of the ribbon to a friend. How much ribbon does Tia have left?” The teacher uses questioning and prompting to have students identify what operation must be used to solve the problem. The teacher asks students, “Did Tia give half of the ribbon or half a yard of ribbon to her friend?” Emphasis is placed on the units (e.g., half of the whole ribbon vs. $\frac{1}{2}$ yard of ribbon) while guiding students to identify that they will need to multiply $\frac{3}{8} \times \frac{1}{2}$ to solve. Students solve using the area model and counters. The cells with both color counters indicate the numerator in the solution. This is repeated with similar word problems, using frequent guiding questions to support student understanding.

$$\frac{3}{8} \times \frac{1}{2} = \frac{3}{16}$$

	$\frac{1}{8}$	$\frac{1}{8}$	$\frac{1}{8}$	$\frac{1}{8}$	$\frac{1}{8}$	$\frac{1}{8}$	$\frac{1}{8}$	$\frac{1}{8}$
$\frac{1}{2}$								
$\frac{1}{2}$								

- Instruction includes opportunities to use models when solving problems that involve multiplication of fractions to increase understanding that multiplication does not always result in a larger number. The use of models when multiplying with fractions will enable students to generalize about multiplication algorithms that are based on conceptual understanding.
 - For example, the teacher displays and reads aloud the following problem: “Rosalind spent $\frac{2}{3}$ of an hour helping in the garden. Her sister spent $\frac{1}{2}$ the amount of time as Rosalind did helping in the garden. How much time did Rosalind’s

sister spend helping in the garden?” Students solve the problem using an area model. The teacher uses questioning to help students draw a model to represent the problem. This is repeated with similar word problems involving multiplication of fractions.

$$\frac{2}{3} \times \frac{1}{2} = \frac{2}{6} \text{ or } \frac{1}{3}$$

	—	—	$\frac{1}{3}$
—	—	—	—
$\frac{1}{2}$			

- For example, the teacher displays and reads aloud the following problem: “Astrid spent $\frac{7}{8}$ of an hour reading her book. Elliot spent $\frac{1}{3}$ the amount of time as Astrid did reading. How much time did Elliot spend reading?” Students solve using the area model and counters. The cells with both color counters indicate the numerator in the solution. The teacher uses questioning to help students draw a model to represent the problem. This is repeated with similar word problems involving multiplication of fractions, using frequent guiding questions to support student understanding.

$$\frac{7}{8} \times \frac{1}{3} = \frac{7}{24}$$

	—	—	—	—	—	—	—	$\frac{1}{8}$
—	—	—	—	—	—	—	—	—
$\frac{1}{3}$								
$\frac{1}{3}$								

Instructional Tasks

Instructional Task 1 (MTR.7.1)

Rachel wants to bake her two favorite brownie recipes. One recipe needs $1\frac{1}{2}$ cups of flour and the other recipe needs $\frac{3}{4}$ cups of flour. How much flour does Rachel need to bake her two favorite brownie recipes?

Instructional Task 2 (MTR.7.1)

Shawn finished a 100 meter race in $\frac{3}{8}$ of one minute. The winner of the race finished in $\frac{1}{3}$ of Shawn’s time. How long did it take for the winner of the race to finish?

Instructional Items

Instructional Item 1

Monica has $2\frac{3}{4}$ cups of berries. She uses $\frac{5}{8}$ cups of berries to make a smoothie. She then uses $\frac{1}{2}$ cup for a fruit salad. After she makes her smoothie and fruit salad, how much of the berries will Monica have left?

**The strategies, tasks and items included in the BIG-M are examples and should not be considered comprehensive.*

MA.5.AR.1.3

Benchmark

MA.5.AR.1.3 Solve real-world problems involving division of a unit fraction by a whole number and a whole number by a unit fraction.

Example: A property has a total of $\frac{1}{2}$ acre and needs to be divided equally among 3 sisters. Each sister will receive $\frac{1}{6}$ of an acre.

Example: Kiki has 10 candy bars and plans to give $\frac{1}{4}$ of a candy bar to her classmates at school. How many classmates will receive a piece of a candy bar?

Benchmark Clarifications:

Clarification 1: Instruction includes the use of visual models and equations to represent the problem.

Connecting Benchmarks/Horizontal Alignment

- MA.5.NSO.2.2
- MA.5.FR.2.4

Terms from the K-12 Glossary

Vertical Alignment

Previous Benchmarks

- MA.4.AR.1.3

Next Benchmarks

- MA.6.NSO.2.3

Purpose and Instructional Strategies

The purpose of this benchmark is to connect division of fraction concepts to real-world scenarios (*MTR.7.1*). This work builds on the multiplication of fractions by whole numbers in grade 4 (MA.4.AR.1.3), and prepares them for grade 6 (MA.6.NSO.2.3) where they will solve real-world fraction problems using all four operations with fractions (*MTR.7.1*).

- During instruction, it is important for students to have opportunities to extend their understanding of the meaning of fractions, how many unit fractions are in a whole, and their understanding of division of fractions as involving equal groups or shares and the number of objects in each.
- Students should use visual fraction models and reasoning to solve word problems involving division of fractions.
 - For example, to assist students with solving the problem, “The elephant eats 4 lbs of peanuts a day. His trainer gives him $\frac{1}{5}$ of a pound at a time. How many times a day does the elephant eat peanuts?” use the following diagram to show how $4 \div \frac{1}{5}$ can be visualized to assist students with solving.

1 lb. of peanuts

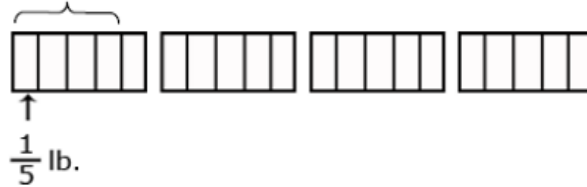

- The expectation of this benchmark is not for students to use an algorithm (e.g., multiplicative inverse) to divide fractions.
- Instruction includes students using equivalent fractions to simplify answers; however, putting answers in simplest form is not a priority.

Common Misconceptions or Errors

- Students may believe that division always results in a smaller number, which is true when dividing a fraction by a whole number, but not when dividing a whole number by a fraction. Using models will help students develop the understanding needed for computation with fractions.

Strategies to Support Tiered Instruction

- Instruction includes opportunities to engage in teacher-directed practice using visual representations to solve real-world problems involving division of a unit fraction by a whole number or a whole number by a unit fraction. The teacher directs students on how to use models or equations based on real-world situations. Through questioning, the teacher guides students to explain what each fractional portion represents in the problems used during instruction and practice.

- For example, the teacher displays and reads aloud the following problem: “Julio has 6 packages of cookies. He is making gift bags for people at school. Each bag will contain $\frac{1}{3}$ of a package of cookies. How many gift bags can he make?”

Using models, the teacher solves the problem with guided questioning having students explain how to use models to solve this question. The teacher guides students to create an equation to represent the problem. This is repeated with multiple real-world examples that involve division of a unit fraction by a whole number or a whole number by a unit fraction.

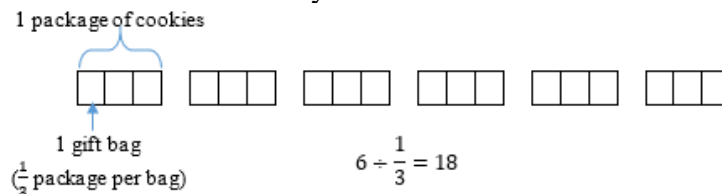

- Teacher provides opportunities to use hands-on models and manipulatives to solve real-world problems involving division of a unit fraction by a whole number or a whole number by a unit fraction. Students explain how each model represents the real-world situation. The teacher directs students how to use models or equations based on real-world examples and through questioning guide students to explain what each fractional portion represents in the problems used during instruction and practice.
- For example, the teacher displays and reads aloud the following problem: “Shelton made some lemonade. The pitcher of lemonade holds 8 cups. If each of the glasses that he uses can hold $\frac{1}{2}$ cup, how many servings of lemonade can he share?” Using fraction bars or fraction strips, the teacher models solving the

problem with explicit instruction and guided questioning. Students explain how to use fraction bars or fraction strips as a model to solve this question and use an equation to represent the problem. This is repeated with multiple real-world problems that involve multiplication of a whole number by a fraction or a fraction by a whole number.

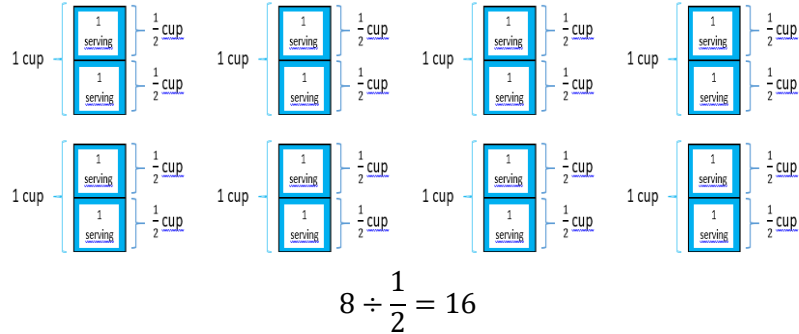

Instructional Tasks

Instructional Task 1 (MTR.6.1, MTR.7.1)

Sonya has $\frac{1}{2}$ gallon of chocolate chip ice cream. She wants to share her ice cream with 6 friends. How much ice cream will each friend get?

Instructional Items

Instructional Item 1

Betty has 12 sheets of tissue paper to add to her holiday gift bags. Each gift bag needs $\frac{1}{3}$ sheet of tissue paper. How many holiday gift bags can Betty fill?

**The strategies, tasks and items included in the BIG-M are examples and should not be considered comprehensive.*

MA.5.AR.2 *Demonstrate an understanding of equality, the order of operations and equivalent numerical expressions.*

MA.5.AR.2.1

Benchmark

MA.5.AR.2.1 Translate written real-world and mathematical descriptions into numerical expressions and numerical expressions into written mathematical descriptions.

Example: The expression $4.5 + (3 \times 2)$ in word form is *four and five tenths plus the quantity 3 times 2.*

Benchmark Clarifications:

Clarification 1: Expressions are limited to any combination of the arithmetic operations, including parentheses, with whole numbers, decimals and fractions.

Clarification 2: Within this benchmark, the expectation is not to include exponents or nested grouping symbols.

Connecting Benchmarks/Horizontal Alignment

- MA.5.NSO.1
- MA.5.NSO.2.3
- MA.5.AR.3.1
- MA.5.M.1.1

Terms from the K-12 Glossary

- Expression

Vertical Alignment

Previous Benchmarks

- MA.4.AR.2.2

Next Benchmarks

- MA.6.AR.1.1

Purpose and Instructional Strategies

The purpose of this benchmark is for students to translate between numerical and written mathematical expressions. This builds from previous work where students wrote equations with unknowns in any position of the equation in grade 4 (MA.4.AR.2.2). Algebraic expressions are a major theme in grade 6 starting with MA.6.AR.1.1.

- During instruction, teachers should model how to translate numerical expressions into words using correct vocabulary. This includes naming fractions and decimals correctly. Students should use diverse vocabulary to describe expressions.
 - For example, in the expression $4.5 + (3 \times 2)$ could be read in multiple ways to show its operations. Students should explore them and find connections between their meanings (*MTR.3.1, MTR.4.1, MTR.5.1*).
 - *4 and five tenths plus the quantity 3 times 2*
 - *4 and 5 tenths plus the product of 3 and 2*
 - *The sum of 4 and 5 tenths and the quantity 3 times 2*
 - *The sum of 4 and 5 tenths and the product of 3 and 2*
- The expectation of this benchmark is to not use exponents or nested grouping symbols. Nested grouping symbols refer to grouping symbols within one another in an expression, like in $3 + [5.2 + (4 \times 2)]$.
- Instruction of this benchmark helps students understand the order of operations, the expectation of MA.5.AR.2.2.

Common Misconceptions or Errors

- Students can misrepresent decimal and fraction numbers in words. This benchmark helps students practice naming numbers according to place value.
- Some students can confuse the difference between what is expected in the expressions $5(9 + 3)$ and $5 + (9 + 3)$. Students need practice naming the former as multiplication (e.g., *5 times the sum of 9 and 3*) and understanding that in that expression, both 5 and $9 + 3$ are factors.

Strategies to Support Tiered Instruction

- Instruction includes opportunities to name fractions and decimals correctly according to place value. The teacher provides students a place value chart to support correctly naming decimals. Students use appropriate terminology for naming fractions.



- For example, write 8.601 in standard form and word form in a place value chart.

	tens	ones	tenths	hundredths	thousandths
Standard form		8	6	0	1
Word form		<i>eight and</i>			<i>six hundred one thousandths</i>

- For example, students write 10.36 in standard form and word form in a place value chart.

	tens	ones	tenths	hundredths	thousandths
Standard form	1	0	3	6	
Word form		<i>ten and</i>		<i>thirty – six hundredths</i>	

- For example, students write 2.47 in standard form and word form in a place value chart using place value disks.

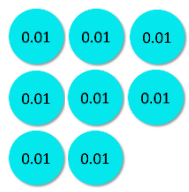
	tens	ones	tenths	hundredths
Standard form		2	4	7
Word form		<i>two and</i>		<i>forty – seven hundredths</i>
Visual representation				

- For example, students write $\frac{5}{12}$ in word form (*five twelfths*).
- For example, students write $2\frac{7}{8}$ in word form (*two and seven eighths*).

This is repeated with additional fractions and decimals.

- Instruction includes opportunities to correctly translate numerical expressions into words using appropriate vocabulary.
 - For example, the teacher has students read aloud the following expression and write in word form. Next, the teacher models one way of reading aloud and has students provide alternate ways while using questioning to facilitate the conversation about the multiple ways the expression can be read aloud to show its operations.

$$18.49 - (27 \div 3)$$

-
- Eighteen and forty-nine hundredths minus the quotient of twenty-seven divided by three.
 - 18 and 49 hundredths minus the quantity 27 divided by 3.
 - The difference between 18 and 49 hundredths and the quotient of 27 divided by 3.
 - The difference between 18 and 49 hundredths and the quantity 27 divided by 3.
- For example, the teacher models how to translate the expression $5(9 + 3)$ into words (e.g., 5 times the sum of 9 and 3) and explains that in this expression, both 5 and $9 + 3$ are factors.

Instructional Tasks

Instructional Task 1 (MTR.4.1)

Nadia sees the numerical expression $6.5 + \frac{1}{2}(4 - 2)$. She translates the expression as, “6 and five tenths plus 1 half times 4, minus 2.”

Part A: Is her translation correct? Explain.

Part B: Evaluate the expression.

Instructional Task 2 (MTR.3.1)

Translate the written mathematical description below into a numerical expression:

Divide the difference of 20 and 5 by the sum of 4 and 1.

Instructional Items

Instructional Item 1

Translate the numerical expression below into a written mathematical description.

$$2(53.8 + 4 - 22.9)$$

Instructional Item 2

Translate the written mathematical description into a numerical expression.

“one half the difference of 6 and 8 hundredths and 2”

**The strategies, tasks and items included in the BIG-M are examples and should not be considered comprehensive.*

Benchmark

MA.5.AR.2.2 Evaluate multi-step numerical expressions using order of operations.

Example: Patti says the expression $12 \div 2 \times 3$ is equivalent to 18 because she works each operation from left to right. Gladys says the expression $12 \div 2 \times 3$ is equivalent to 2 because first multiplies 2×3 then divides 6 into 12. David says that Patti is correctly using order of operations and suggests that if parentheses were added, it would give more clarity.

Benchmark Clarifications:

Clarification 1: Multi-step expressions are limited to any combination of arithmetic operations, including parentheses, with whole numbers, decimals and fractions.

Clarification 2: Within this benchmark, the expectation is not to include exponents or nested grouping symbols.

Clarification 3: Decimals are limited to hundredths. Expressions cannot include division of a fraction by a fraction.

Connecting Benchmarks/Horizontal Alignment

- MA.5.NSO.1
- MA.5.NSO.2.3 MA.5.NSO.2.4, MA.5.NSO.2.5
- MA.5.FR.1.1
- MA.5.FR.2.1

Terms from the K-12 Glossary

- Expression
- Order of Operations

Vertical Alignment

Previous Benchmarks

- MA.4.AR.2.1, MA.4.AR.2.2

Next Benchmarks

- MA.6.NSO.2.3
- MA.6.AR.1.3

Purpose and Instructional Strategies

The purpose of this benchmark is for students to use the order of operations to evaluate numerical expressions. In grade 4, students had experience with numerical expressions involving all four operations (MA.4.AR.2.1/2.2), but the focus was not on order of operations. In grade 6, students will be evaluating algebraic expressions using substitution and these expressions can include negative numbers (MA.6.AR.1.3).

- Begin instruction by exposing student to expressions that have two operations without any grouping symbols, before introducing expressions with multiple operations. Use the same digits, with the operations in a different order, and have students evaluate the expressions, then discuss why the value of the expression is different.
 - For example, have students evaluate $6 \times 3 + 7$ and $6 + 3 \times 7$.
- In grade 5, students should learn to first work to simplify within any parentheses, if present in the expression. Within the parentheses, the order of operations is followed. Next, while reading left to right, perform any multiplication and division in the order in which it appears. Finally, while reading from left to right, perform addition and subtraction in the order in which it appears.

- During instruction, students should be expected to explain how they used the order of operations to evaluate expressions and share with others. To address misconceptions around the order of operations, instruction should include reasoning and error analysis tasks for students to complete (*MTR.3.1, MTR.4.1, MTR.5.1*).

Common Misconceptions or Errors

- When students learn mnemonics like PEMDAS to perform the order of operations, they can confuse that multiplication must always be performed before division, and likewise addition before subtraction. Students should have experiences solving expressions with multiple instances of procedural operations and their inverse, such as addition and subtraction, so they learn how to solve them left to right.

Strategies to Support Tiered Instruction

- Instruction includes opportunities to solve expressions with multiple instances of procedural operations and their inverse, explicitly teaching the order of operations with an emphasis on the left to right order to solving multiplication and division, and addition and subtraction. Students use models or drawings as they solve.
 - For example, the teacher displays the following problem: $62 - 8 \times 4 + 3 - (18 \div 9)$. The teacher reviews the order of operations, reminding students that they must work to simplify within the parentheses first. The teacher then prompts students to multiply and divide from left to right next. Then, students are prompted to add and subtract from left to right and reminded that adding and subtracting fall within the same step. So, they will need to subtract $62 - 32$ to get 30 and then add $30 + 3$. The teacher repeats with additional expressions containing multiplication, division, addition, and subtraction in a variety of orders.

Step 1: Parentheses	$62 - 8 \times 4 + 3 - (18 \div 9)$
Step 2: Multiplication and division	$62 - 8 \times 4 + 3 - 2$
Step 3: Addition and subtraction	$62 - 32 + 3 - 2$ $30 + 3 - 2$ $33 - 2$
Solution	31

- Instruction includes manipulatives to practice solving expressions with multiple instances of procedural operations and their inverse, such as addition and subtraction, so they learn how to solve them left to right. Instruction also includes explicitly teaching the order of operations with an emphasis on the left to right order to solving multiplication and division, and addition and subtraction. Students use manipulatives as they solve.
 - For example, display the following problem: $5 - 10 \div 5 + (2 \times 3)$. The teacher reviews the order of operations, reminding students that they must work to simplify within the parentheses first. The teacher prompts students to multiply and divide from left to right next. Then, prompts students to add and subtract from left to right. Finally, the teacher reminds students that adding and subtracting falls within the same step, so they will need to subtract $5 - 2$ before they add $+6$. This is repeated with additional expressions containing multiplication, division, addition, and subtraction in a variety of orders.

Step 1: Parentheses	$5 - 10 \div 5 + 2 - 3$
Step 2: Multiplication and division	$5 - 10 \div 5 + 6$
Step 3: Addition and subtraction	$5 - 2 + 6$ $3 + 6$
Solution	9

Instructional Tasks

Instructional Task 1 (MTR.4.1)

The two equations below are very similar. Are both equations true? Why or why not?

$$\text{Equation One: } 4 \times 6 + 3 \times 2 + 4 = 34$$

$$\text{Equation Two: } 4 \times (6 + 3 \times 2 + 4) = 64$$

Instructional Task 2 (MTR.5.1)

Part A. Insert one set of parentheses around two numbers in the expression below. Then evaluate the expression.

$$40 \div 5 \times 2 + 6$$

Part B. Now insert one set of parentheses around a different pair of numbers. Then evaluate this expression.

$$40 \div 5 \times 2 + 6$$

Instructional Items

Instructional Item 1

What is the value of the numerical expression below:

$$(2.45 + 3.05) \div (7.15 - 2.15)$$

Instructional Item 2

A numerical expression is evaluated as shown.

$$\frac{1}{2} \times (3 \times 5 + 1) - 2$$

In which step does the first mistake appear

- Step 1: $\frac{1}{2} \times (15 + 1) - 2$
- Step 2: $\frac{1}{2} \times 14$
- Step 3: $\frac{14}{2}$
- Step 4: 7

*The strategies, tasks and items included in the BIG-M are examples and should not be considered comprehensive.

Benchmark

MA.5.AR.2.3 Determine and explain whether an equation involving any of the four operations is true or false.

Example: The equation $2.5 + (6 \times 2) = 16 - 1.5$ can be determined to be true because the expression on both sides of the equal sign are equivalent to 14.5.

Benchmark Clarifications:

Clarification 1: Problem types include equations that include parenthesis but not nested parentheses.

Clarification 2: Instruction focuses on the connection between properties of equality and order of operations.

Connecting Benchmarks/Horizontal Alignment

- MA.5.NSO.1
- MA.5.NSO.2.1, MA.5.NSO.2.3, MA.5.NSO.2.5

Terms from the K-12 Glossary

- Equal Sign
- Equation
- Expression

Vertical Alignment

Previous Benchmarks

- MA.4.AR.2.1

Next Benchmarks

- MA.6.AR.2.1

Purpose and Instructional Strategies

The purpose of this benchmark is to determine if students can connect their understanding of using the four operations reliably or fluently (*MTR.3.1*) to the concept of the meaning of the equal sign. Students have evaluated whether equations are true or false since grade 2. In grade 5, additional expectations include non-whole numbers and parentheses. In grade 6, students extend this work to involve negative numbers and inequalities (MA.6.AR.2.1).

- Students will use their understanding of order of operations (MA.5.AR.2.2) to simplify expressions on each side of an equation (*MTR.5.1*).
- Students will determine if the expression on the left of equal sign is equivalent to the expression to the right of the equal sign. If these expressions are equivalent, then the equation is true.
- Students may use comparative relational thinking, instead of solving, in order to determine if the equation is true or false (*MTR.2.1, MTR.3.1, MTR.5.1*).

Common Misconceptions or Errors

- Some students may not understand that the equal sign is a relational symbol showing expressions on both sides that are the same. While justifying whether equations are true or false, students should explain what makes the equation true.



Strategies to Support Tiered Instruction

- Instruction includes opportunities to explore the meaning of the equal sign. The teacher provides explicit clarification that the equal sign means “the same as” rather than “the answer is” along with multiple examples for students to evaluate equations as true or false using the four operations with the answers on both the left and right side of the equation. Instruction begins by using single numbers on either side of the equal sign to build understanding using the same equations written in different ways to reinforce the concept.
 - For example, the teacher shows the following equations, asking students if they are true or false statements. Students explain why each equation is true or false. This is repeated with additional true and false equations using the four operations.

Example	True/False	Sample Student Rationale
$\frac{2}{10} = \frac{1}{5}$	True	They are both the same value; $\frac{2}{10}$ is equivalent to $\frac{1}{5}$.
$9 \div 2 = 3$	False	Nine and three have different values; they are not the same.
$2 + 11 = 13$	True	When you add two and eleven, the total has a value of thirteen.
Three cookies shared among 5 friends is equivalent to $\frac{3}{5}$.	True	The fractional value of the cookies that each friend will get is equal to $\frac{3}{5}$.
$4 + 2 = 42$	False	The sum of four and two is six, not forty-two.
$4 + 1 = 2 + 3$	True	Four plus one has a value of five. Two plus three also has a value of five.
$2 \times 2 = 8 \div 2$	True	Two times two has a value of four. Eight divided two also has a value of four.
$(3 + 1) \times 2 = 16 \div 2$	True	Three plus one is four and four times two is eight. Sixteen divided by two is also eight.
$18 \div (1.5 \times 2) = (18 \div 2) + 3$	False	One and five-tenths times two is three. Eighteen divided by three is six. Eighteen divided by two is nine. Nine plus three is twelve. Six is not equal to twelve.

- For example, the teacher shows the following equations having students use counters, drawings, or base-ten blocks on a t-chart to represent the equation. The teacher asks students if they are true or false statements and to explain what makes equations true. This is repeated with additional true and false equations using the four operations.

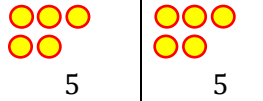
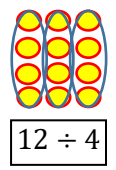
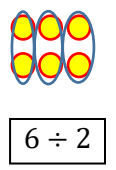
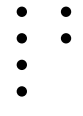
Example	Visual Representation	True/False	Sample Student Rationale

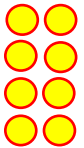
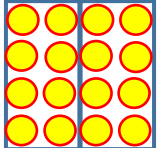
$5 = 5$		True	They are both the same number; the same amount is on both sides.	
$12 \div 4 = 6 \div 2$			True	Twelve divided into groups of 4 equals 3 whole groups. Six divided into groups of 2 also equals 3 whole groups.
$4 + 2 = 42$			False	The sum of four and two is six, not forty-two. The value on each side is different.
$(3 + 1) \times 2 = 16 \div 2$			True	Three plus one is four and four times two is eight. Sixteen divided by two is also eight.

Instructional Tasks

Instructional Task 1 (MTR.2.1)

Using the numbers below, create an equation that is true.

$$(\quad \times \quad) - \quad = \quad - \quad$$

12, 6.2, $5\frac{1}{5}$, 4, 3.5

Instructional Items

Instructional Item 1

Which best explains the equation below?

$$13.8 - 6 + 3 = 4 \times 1.2$$

- This equation is true because both sides of the equation are equal to 4.8.
- This equation is true because both sides of the equation are equal to 10.8.
- This equation is false because both sides of the equation are equal to 4.8.
- This equation is false because both sides of the equation are unequal.

*The strategies, tasks and items included in the BIG-M are examples and should not be considered comprehensive.

Benchmark

MA.5.AR.2.4 Given a mathematical or real-world context, write an equation involving any of the four operations to determine the unknown whole number with the unknown in any position.

Example: The equation $250 - (5 \times s) = 15$ can be used to represent that 5 sheets of paper are given to s students from a pack of paper containing 250 sheets with 15 sheets left over.

Benchmark Clarifications:

Clarification 1: Instruction extends the development of algebraic thinking where the unknown letter is recognized as a variable.

Clarification 2: Problems include the unknown and different operations on either side of the equal sign.

Connecting Benchmarks/Horizontal Alignment

- MA.5.NSO.2.1, MA.5.NSO.2.2
- MA.5.AR.1.1
- MA.5.AR.3.1

Terms from the K-12 Glossary

- Equal Sign
- Equation
- Expression
- Whole Number

Vertical Alignment

Previous Benchmarks

- MA.4.AR.2.2

Next Benchmarks

- MA.6.AR.1.4
- MA.6.AR.2

Purpose and Instructional Strategies

The purpose of this benchmark is for students to write equations that determine unknown whole numbers from mathematical and real-world contexts. In grade 4, students wrote equations from mathematical and real-world contexts to determine unknown whole numbers (represented by letter symbols) (MA.4.AR.2.2). The extension in grade 5 is that factors are not limited to within 12 and equations may use parentheses, implying students may have to use the order of operations to solve. In grade 6, students extend this work to include integers and positive fractions and decimals.

- Instruction should focus on helping students translate mathematical and real-world contexts to equations. Instructional emphasis should be placed on students' comprehension of the contexts to then translate to equations more easily. An instructional strategy that helps students translate from context to symbolic equations is to first present contexts with some or all their numerical information omitted. In a mathematical context, this may look like showing a data display with some numerical information covered. In a real-world context, this may look like a word problem with quantities covered. This allows students to comprehend what the problem trying to find and allows students to think deeper about what operations will be required to do so. It can also help students estimate reasonable solution ranges. Once students can predict an equation (or equations) to solve the problem, then the teacher can reveal all numerical information and allow students to solve (*MTR.5.1*).

- In each context, students may provide many examples of equations that can be used to solve. During instruction, teachers should have students compare their equations and evaluate whether they can be used to solve (*MTR.4.1*).
- During instruction, students should justify how their equations match the mathematical and real-world contexts through checking solutions. Students should substitute their solution for their letter symbol and use the order of operations to check that it makes the equation true.

Common Misconceptions or Errors

- When students have trouble comprehending contexts, they tend to just grab numbers from a given context and begin computing without justifying their arguments. Emphasis of instruction should be on the comprehension of problems through classroom discussion, sharing strategies, estimating reasonable solutions, and justifying equations and solutions.

Strategies to Support Tiered Instruction

- Instruction focuses on the comprehension of problems through classroom discussion, sharing strategies, estimating reasonable solutions, and justifying equations and solutions.
- Instruction includes opportunities to connect real-world situations to write equations using any of the four operations to determine an unknown whole number with the unknown in any position. Students apply the order of operations to solve for the unknown. The teacher emphasizes the inverse relationships between addition and subtraction, and multiplication and division as applicable in order to help students solve for the unknown, while reinforcing conceptual understanding by having students use drawings, models and equations to solve real world problems.
 - For example, the teacher displays and reads the following problem aloud: “Renaldo read the same number of pages of his book each day for 8 days. He needs to read a total of 315 pages, and still needs to read 155 pages to meet his goal. How many pages did he read on each of the 8 days so far?” Students are provided manipulatives, such as counters or base-ten blocks, to model the problem or to use a drawing, such as a bar model, to solve and to write an equation. Through prompting and questioning, students explain their models, justify their solutions, and check their solution, repeating with multiple examples of real-world problems.

$$(8 \times n) + 155 = 315$$

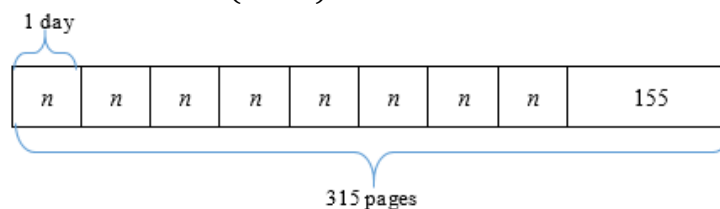

$$(8 \times n) = 315 - 155$$

$$315 - 155 = 160 \text{ pages}$$

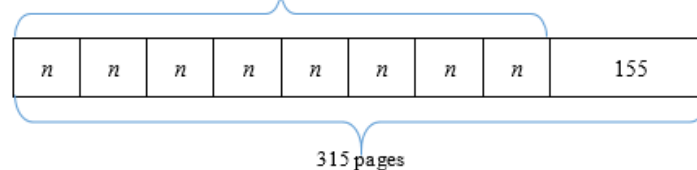

$$315 - 155 = 160$$

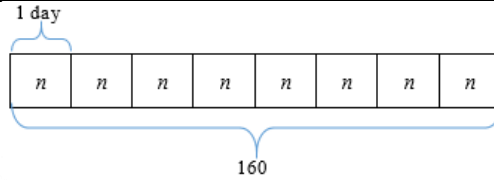

$$8 \times n = 160$$

$$160 \div 8 = n$$

$$160 \div 8 = 20$$

$$n = 20$$

- For example, Elijah reads 25 pages of a novel per day for 7 days. The entire novel is 230 pages, how many pages does he have left to read? Students are provided manipulatives, such as counters or base-ten blocks, to model the problem or to use a drawing, such as a bar model, to solve and to write an equation. Through prompting and questioning, students explain their models, justify their solutions, and check their solution, repeating with multiple examples of real-world problems.

$$25 \times 7 + p = 230$$

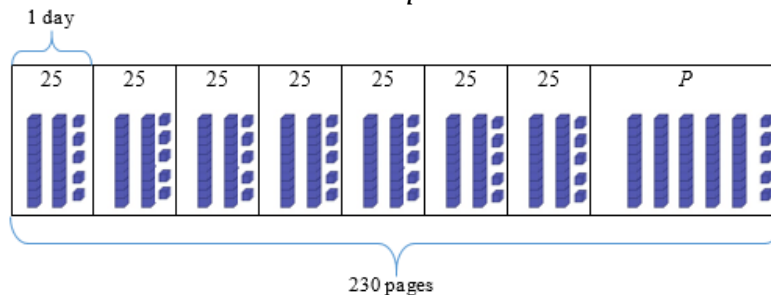

$$25 \times 7 + p = 230$$

$$175 + p = 230$$

$$230 - 175 = p$$

$$230 - 175 = 55$$

$$p = 55$$

Instructional Tasks

Instructional Task 1 (MTR.7.1)

To celebrate reaching their monthly reading goal, Dr. Ocasio’s class has a cookie party. Dr. Ocasio buys a box of 96 cookies. She plans to give the same number to each of the 21 students in her class. She wants 12 cookies remaining to bring home for her children. What is the greatest number of cookies each of Dr. Ocasio’s students can receive?

Part A. Write an equation that can be used to solve. Use a letter to represent the unknown number.

Part B. What is the greatest number of cookies each of Dr. Ocasio’s students can receive?

Part C. Prove that your answer is correct by showing how your equation is true.

Instructional Items

Instructional Item 1

Which of the equations can be used to solve the problem below?

To celebrate reaching their monthly reading goal, Dr. Ocasio’s class has a cookie party. Dr. Ocasio buys a box of 96 cookies. She plans to give the same number to each of the 21

students in her class. She wants 12 remaining to bring home for her children. What is the greatest number of cookies each of Dr. Ocasio’s students can receive?

- a. $96 - 21 - 12 = c$
- b. $96 - (21 \times c) = 12$
- c. $12 + c = 96 - 21$
- d. $21 \times c + 12 = 96$

**The strategies, tasks and items included in the BIG-M are examples and should not be considered comprehensive.*

MA.5.AR.3 Analyze patterns and relationships between inputs and outputs.

MA.5.AR.3.1

Benchmark

MA.5.AR.3.1 Given a numerical pattern, identify and write a rule that can describe the pattern as an expression.

Example: The given pattern 6, 8, 10, 12 ... can be described using the expression $4 + 2x$, where $x = 1, 2, 3, 4 \dots$; the expression $6 + 2x$, where $x = 0, 1, 2, 3 \dots$ or the expression $2x$, where $x = 3, 4, 5, 6 \dots$

Benchmark Clarifications:

Clarification 1: Rules are limited to one or two operations using whole numbers.

Connecting Benchmarks/Horizontal Alignment

- MA.5.AR.2.1, MA.5.AR.2.4

Terms from the K-12 Glossary

- Coefficient

Vertical Alignment

Previous Benchmarks

- MA.4.AR.3.2

Next Benchmarks

- MA.6.AR.3.3

Purpose and Instructional Strategies

The purpose of this benchmark is for students to identify and write an expression that shows the rule for a given pattern. Students have been identifying and generating patterns since grade 3. In grade 5, the expectation extends to students writing a rule as an expression that may have 1 or 2 operations. In grade 6, the focus is on patterns involving ratios (MA.6.AR.3.3).

- The rules for given patterns are limited to one or two operations using whole numbers.
- Vocabulary (e.g., coefficient, terms, variables) should be interwoven into instruction of this benchmark. These terms are introduced in grade 5, but not expected to be mastered until grade 6.
- Students should understand that determining a rule for patterns helps them determine the value of future terms in the pattern (*MTR.2.1, MTR.5.1*).
- During instruction, teachers can have students compare their rules and justify them using properties of operations.
 - For example, have students determine why the rule for the pattern in the benchmark example could be $6 + 2x$ or $2x + 6$ (*MTR.5.1, MTR.6.1*).

- Instruction of this benchmark should be paired with MA.5.AR.3.2. The combination of determining rules and completing tables is important for students to begin understanding ratios and functions in the middle grades (*MTR.5.1*).
- Instruction includes recognizing patterns that arise from geometrical figures with different lengths and their perimeter or area.
 - For example, a pattern can arise from the following sequence of rectangles: 1 unit by 1 unit, 1 unit by 2 units, 1 unit by 3 units, 1 unit by 4 units. Students can describe the pattern of the perimeter or of the area.

Common Misconceptions or Errors

- A common mistake that students make is to determine a rule based on the change in only the first two terms. During instruction, teachers should emphasize that a rule must work for the change in any two terms in a pattern.

Strategies to Support Tiered Instruction

- Instruction includes opportunities to determine a rule given a numerical expression. After determining the rule, teachers provide guidance to support students as they work to describe the pattern as an expression. Special attention should be given to ensure that the rule is based on changes in all terms within the pattern (not just the first two terms).

- For example, the teacher provides students with the first four terms of a pattern:

3, 8, 13, 18 ...

The teacher guides students to notice what pattern they see between the four terms (each number is five greater than the previous number). If students have difficulty, a number line or hundreds chart may be used to support finding the pattern. Students should identify that the rule is to add five. Based on this rule, the teacher guides students to represent the pattern as an expression (e.g., $3 + 5x$, where $x = 0, 1, 2, 3 \dots$) having students use the expression to check for accuracy with each of the terms in the pattern and identify the next two terms in the pattern (... 23, 28 ...).

- For example, the teacher provides students with the first four terms of a pattern.

6, 10, 14, 18 ...

The teacher guides students to notice what patterns they see between the four terms (each number is four greater than the previous number). A number line or hundreds chart is used to support finding the pattern. Students identify that the rule is to add four. Based on this rule, the teacher guides students to represent the pattern as an expression (e.g., $6 + 4x$, where $x = 0, 1, 2, 3 \dots$) having students use the expression to check for accuracy with each of the terms in the pattern and identify the next two terms in the pattern (... 22, 26 ...).

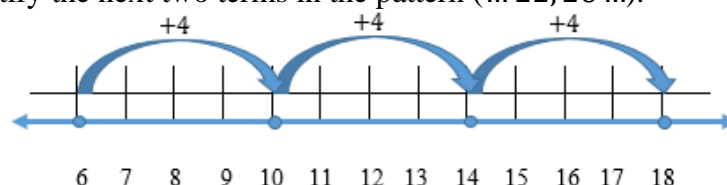

Instructional Tasks

Instructional Task 1 (*MTR.5.1*)

The first four terms of a pattern are below.

9, 13, 17, 21, ...

Part A. Write a mathematical description for a rule that matches these terms.

Part B. Write an expression that describes your rule.

Part C. Use your answer from Part B to determine the value of the 16th term.

Instructional Items

Instructional Item 1

Write an expression that can be a rule for the terms shown below.

2, 7, 12, 17, ...

**The strategies, tasks and items included in the BIG-M are examples and should not be considered comprehensive.*

MA.5.AR.3.2

Benchmark

MA.5.AR.3.2 Given a rule for a numerical pattern, use a two-column table to record the inputs and outputs.

Example: The expression $6 + 2x$, where x represents any whole number, can be represented in a two-column table as shown below.

Input (x)	0	1	2	3
Output	6	8	10	12

Benchmark Clarifications:

Clarification 1: Instruction builds a foundation for proportional and linear relationships in later grades.

Clarification 2: Rules are limited to one or two operations using whole numbers.

Connecting Benchmarks/Horizontal Alignment

Terms from the K-12 Glossary

- MA.5.GR.4.2

Vertical Alignment

Previous Benchmarks

- MA.4.AR.3.2

Next Benchmarks

- MA.6.AR.3.3

Purpose and Instructional Strategies

The purpose of this benchmark is to relate patterns to a two-column table for students to record inputs and outputs. It is related to MA.5.AR.3.1 where students determine rules from given patterns. This is the first grade in which students record inputs and outputs two-column tables, and this work helps build the foundation for proportional relationships (MA.6.AR.3.3 and MA.7.AR.4) in middle school and functional relationships starting in grade 8.

- Instruction of this benchmark should be paired with MA.5.AR.3.1. Organizing patterns into input and output tables lays the foundation for students to explore proportional and linear relationships in later grades (*MTR.5.1*).
- During instruction, teachers can relate the idea of “inputs” and “outputs” on a two-column table to a machine. The input is the term number, and the output is the corresponding term’s value. Students are to find what the machine does to determine the output.
- Instruction should make connections between representing the information in a two-column table and as ordered pairs on a coordinate plane (MA.5.GR.4.2).

Common Misconceptions or Errors

- Students may make computational errors when calculating the output for a given rule and input.
- Students may confuse input and output values when recording the values in a two-column table.

Strategies to Support Tiered Instruction

- Instruction includes opportunities to record each step when calculating the output for a given rule and input.
 - For example, for the rule $8 + 3x$ students record the steps to calculate the output using an input of 5 and the order of operations.

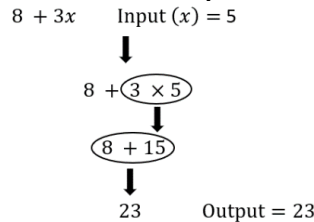

- Instruction includes using highlighters when recording inputs and outputs in a two-column table. Students highlight the “inputs” label in the table and all corresponding inputs using one color. Then, students highlight the “outputs” label in the table and all corresponding outputs using a different color.



Instructional Tasks

Instructional Task 1 (MTR.5.1)

The Math Machine makes two-column tables when the user tells it a rule. Jacob tells the Math Machine to create a table using the rule “ $10 + 2x$.” Unfortunately, the machine is malfunctioning and only some of the table is correct.

Part A: Identify which values are incorrect and complete the table correctly.

Input (x)	0	1	2	3
Output	12	12	22	32

Part B: Extend your table to show the outputs for $x = 10, 11$ and 12 .

Instructional Items

Instructional Item 1

What is the missing value in the two-column table below?

Rule: $40 - 3x$

Input (x)	0	1	2	3
Output	?	37	34	31

**The strategies, tasks and items included in the BIG-M are examples and should not be considered comprehensive.*

Measurement

MA.5.M.1 Convert measurement units to solve multi-step problems.

MA.5.M.1.1

Benchmark

MA.5.M.1.1

Solve multi-step real-world problems that involve converting measurement units to equivalent measurements within a single system of measurement.

Example: There are 60 minutes in 1 hour, 24 hours in 1 day and 7 days in 1 week. So, there are $60 \times 24 \times 7$ minutes in one week which is equivalent to 10,080 minutes.

Benchmark Clarifications:

Clarification 1: Within the benchmark, the expectation is not to memorize the conversions.

Clarification 2: Conversions include length, time, volume and capacity represented as whole numbers, fractions and decimals.

Connecting Benchmarks/Horizontal Alignment

Terms from the K-12 Glossary

- MA.5.NSO.1.1
- MA.5.NSO.2.1, MA.5.NSO.2.4, MA.5.NSO.2.5
- MA.5.AR.1.2
- MA.5.AR.2.1
- MA.5.M.2.1
- MA.5.GR.1.1
- MA.5.GR.2.1
- MA.5.GR.3.3

Vertical Alignment

Previous Benchmarks

- MA.4.M.1.2

Next Benchmarks

- MA.6.AR.3.5

Purpose and Instructional Strategies

The purpose of this benchmark is for students to be able to understand the relationship between units of measure through problem solving. This benchmark builds on grade 4 concepts of converting measurement units (MA.4.M.1.2), and becomes a part of a larger context of ratios and rates in grade 6 (MA.6.AR.3.5).

- Instruction allows students to convert measurements flexibly.
 - For example, when finding the number of inches in 2 yards, students may start with inches, feet or yards when calculating. Classroom discussion should compare those conversions to explore their similarities and differences (*MTR.2.1, MTR.4.1*).
- For students to have a better understanding of the relationships between units, it is important for teachers to allow students to have practice with tools during instruction. This will show students how the number of units relates to the size of the unit.
 - For example, for students to discover converting inches to yards, teachers can have them use 12-inch rulers and yardsticks. This will allow students to see that three of the 12-inch rulers are equivalent to one yardstick ($3 \times 12 \text{ inches} =$

36 inches; 36 inches = 1 yard), so that students understand that there are 12 inches in 1 foot and 3 feet in 1 yard. Using this knowledge, students will be able to determine whether to multiply or divide when making conversions (*MTR.2.1*).

- When moving into real-world problem solving, it is important to begin with problems that allow for renaming the units to represent the solution before using problems that require renaming to find the solution (*MTR.7.1*).

Common Misconceptions or Errors

- Students confuse renaming units of measurement with the renaming that they do with whole numbers and place value.
 - For example, when subtracting 6 inches from 3 feet, they get 2 feet 4 inches because they think of subtracting 6 inches from 30 inches. Students need to pay attention to the unit of measurement which dictates the renaming (inches in this example) and the number to use (12 inches in a foot instead of 10 inches in a foot).

Strategies to Support Tiered Instruction

- Instruction includes deciding which operation to use when converting from smaller units to larger units (e.g., ounces to pounds) and when converting from larger units to smaller units (e.g., pounds to ounces). Instruction should also include estimating reasonable solutions.
 - For example, the teacher models a think aloud for which numbers to use based on the units of measurement and record the relationships on a chart.
 - How many minutes are in 1 week?
 - There are 60 minutes in 1 hour, 24 hours in 1 day and 7 days in 1 week. So, there are $60 \times 24 \times 7$ minutes in one week which is equivalent to 10,080 minutes.

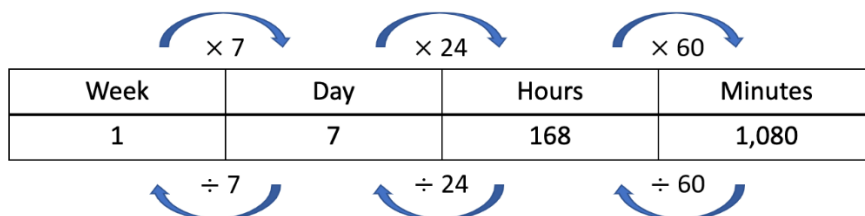

- Instruction includes using a bar model or tape diagram to show the relationship between the units.

Instructional Tasks

Instructional Task 1 (MTR.6.1, MTR.7.1)

Zevah is helping her mom plan her sister's surprise birthday party.

Part A. The recipe to make one bowl of punch is shown below. How many cups of punch will they be able to serve at the party if they only make one bowl of punch and there is no punch leftover in the bowl?

Liquid	Fluid Ounces
Pineapple Juice	32 oz
Fruit Punch	64 oz
Ginger Ale	76 oz

Part B. At the party, Zevah wants each balloon to have a string that is 250 centimeters long. The string she wants to buy comes in rolls of 30 meters. How many rolls of string does Zevah need to buy if she plans to have 36 balloons at the party?

Instructional Items

Instructional Item 1

Michael is measuring fabric for the costumes of a school play. He needs 11.5 meters of fabric. He has 280 centimeters of fabric. How many more centimeters of fabric does he need?

Instructional Item 2

A recipe requires 24 ounces of milk. Edwin has only a $\frac{1}{2}$ cup measuring cup. How many measuring cups of milk will Edwin need?

- a. 6
- b. 12
- c. 18
- d. 24

**The strategies, tasks and items included in the BIG-M are examples and should not be considered comprehensive.*

MA.5.M.2 Solve problems involving money.

MA.5.M.2.1

Benchmark

MA.5.M.2.1 Solve multi-step real-world problems involving money using decimal notation.

Example: Don is at the store and wants to buy soda. Which option would be cheaper: buying one 24-ounce can of soda for \$1.39 or buying two 12-ounce cans of soda for 69¢ each?

Connecting Benchmarks/Horizontal Alignment

- MA.5.NSO.1.1, MA.5.NSO.1.2, MA.5.NSO.1.3
- MA.5.NSO.2.3, MA.5.NSO.2.4, MA.5.NSO.2.5
- MA.5.AR.2.1, MA.5.AR.2.4
- MA.5.M.1.1

Terms from the K-12 Glossary

Vertical Alignment

Previous Benchmarks

- MA.4.M.2.2

Next Benchmarks

- MA.6.NSO.2.3

Purpose and Instructional Strategies

The purpose of this standard is for students to apply understanding of multi-step real-world problems, measurement conversions, and decimal operations to solve problems involving money (*MTR.7.1*). This benchmark connects to previous work in grade 4 where students added and subtracted money in real world situations (MA.4.M.2.2). Money contexts continue to be important throughout the later grades.

- During instruction, teachers should provide strategies for helping students comprehend what is happening in the problem and what needs to be found before students complete numerical calculations. Students should be encouraged to estimate a solution and model a problem using manipulatives, pictures and/or equations before computing (*MTR.2.1*).

Common Misconceptions or Errors

- Students can misinterpret multi-step word problems and only complete one of the steps. Encourage students to estimate reasonable solutions and justify models to solve before computing.

Strategies to Support Tiered Instruction

- Instruction includes encouraging students to estimate reasonable solutions and justify models before performing computations of a multi-step word problem.
- Instruction includes using visual models, such as bar models or tape diagrams, to help to visualize the problem.
 - For example, which is a better deal, buying one 24oz. can for \$1.39 or two 12 oz. cans for \$0.69 each?

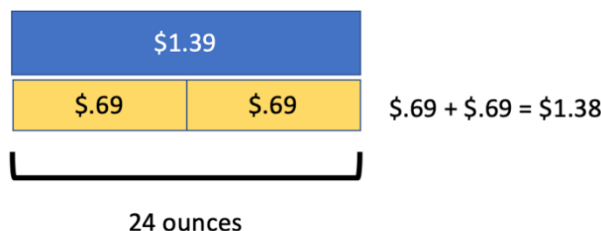

- Instruction includes visualizing word problems. The Three-Reads Protocol is a strategy that can be used to help students conceptualize what the question is asking. Students draw pictures or models to represent what is happening in the word problem. These pictures and models can be used to help students write equations for the problem they are solving.

-
- Instruction includes breaking down word problems into smaller parts. Students use a highlighter to emphasize the important information in the word problem and paraphrase the word problem so the teacher can determine if the student understands what the question is asking.

Instructional Tasks

Instructional Task 1 (MTR.7.1)

Jordan was saving his money to buy a remote control motorcycle. He saved \$37.81 from his allowance and received two checks worth \$10.00 each for his birthday. Jordan also has a half dollar coin collection with 30 coins in it. If the motorcycle costs \$72.29, does Jordan have enough money to buy the motorcycle?

Instructional Items

Instructional Item 1

Pecans and almonds each cost \$6.80 per pound. Kendall buys 1.5 pounds of pecans and 2.5 pounds of almonds. What is the total cost of Kendall's purchase?

Instructional Item 2

A table below shows the costs of items at a candy store.

Item	Cost
Chocolate bar	\$2.99 each
Candy rope	\$0.45 per ounce
Peanut butter cups	\$1.50 each
Bubble gum	\$0.29 per ounce

Wayne has \$10 to spend. Select all the purchases that Wayne has enough money to make.

- a. 3 chocolate bars
- b. 25 ounces of candy rope
- c. 2 chocolate bars and 3 peanut butter cups
- d. 3 peanut butter cups and 5 ounces of bubble gum
- e. 24 ounces of bubble gum and 2 ounces of candy rope

**The strategies, tasks and items included in the BIG-M are examples and should not be considered comprehensive.*

Geometric Reasoning

MA.5.GR.1 *Classify two-dimensional figures and three-dimensional figures based on defining attributes.*

MA.5.GR.1.1

Benchmark

MA.5.GR.1.1 Classify triangles or quadrilaterals into different categories based on shared defining attributes. Explain why a triangle or quadrilateral would or would not belong to a category.

Benchmark Clarifications:

Clarification 1: Triangles include scalene, isosceles, equilateral, acute, obtuse and right; quadrilaterals include parallelograms, rhombi, rectangles, squares and trapezoids.

Connecting Benchmarks/Horizontal Alignment

- There are no direct connections outside of this standard; however, teachers are encouraged to find possible indirect connections.

Terms from the K-12 Glossary

- Acute Triangle
- Equilateral Triangle
- Isosceles Triangle
- Obtuse Triangle
- Parallelograms
- Quadrilateral
- Rectangle
- Rhombus
- Right Triangle
- Scalene Triangle
- Square
- Trapezoid
- Triangle

Vertical Alignment

Previous Benchmarks

- MA.4.GR.1.1

Next Benchmarks

- MA.912.GR.3.2

Purpose and Instructional Strategies

The purpose of this benchmark is for students to understand that shapes can be classified by their attributes and these attributes may place them in multiple categories. In grade 3, students identified and drew quadrilaterals based on their attributes (MA.3.GR.1.2). In grade 4, students explored angle classifications and measures in two-dimensional figures (MA.4.GR.1.1). This past work built the understanding required for students to classify triangles and quadrilaterals in grade 5. Classification of geometric figures will return in high school geometry (MA.912.GR.3.2) using another grade 5 concept, the coordinate plane.

- The work in grade 5 will help students to understand that triangles can be defined by two different attributes that students can measure: the length of their sides (3 congruent sides, 2 congruent sides, or 0 congruent sides) and the size of their angle measures (3 acute angles, 2 acute angles and a right angle, or 2 acute angles and an obtuse angle).
- During instruction, it is important for students to have practice with classifying figures in multiple ways so they can better understand the relationship between attributes of the

geometric figures. In addition, students should practice this concept by using graphic organizers such as, flow charts, T-charts and Venn diagrams (*MTR.2.1*).





- This benchmark requires a strong understanding and use of geometry vocabulary. Allow students to use math discourse throughout instruction to compare the attributes of geometric figures.
 - For example, pose questions such as, “Why is a square always a rhombus?” and “Why is a rhombus not always a square?” Lesson activities should require students to justify their thinking when making mathematical arguments about geometric figures (*MTR.4.1*).

Common Misconceptions or Errors

- Students may think that when describing and classifying geometric shapes and placing them in subcategories, the last subcategory is the only classification that can be used.
- Students may think that a geometric figure can only be classified in one way.
 - For example, a square (a shape with 4 congruent sides and 4 congruent angles) can also be a parallelogram because it contains 2 pairs of sides that are congruent and parallel.

Strategies to Support Tiered Instruction

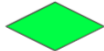



- Instruction includes providing a graphic organizer and having students place triangles and/or quadrilaterals into all the subcategories they belong to. Students then identify all the ways the figure could be classified.
 - For example, students are provided with a graphic organizer like the one shown below to help them classify figures into subcategories. The name of the figure, an example, and the definition are provided. Students then identify which other categories the figure would also fit. For example, a parallelogram is a quadrilateral containing two pairs of parallel sides. A rectangle, rhombus, and square all also have two pairs of parallel sides so they would also fit in this subcategory. The teacher refers to the glossary, included with the standards, for several examples to provide students.

Figure	Definition	Other Figures that Fit in this Category
Parallelogram 	A quadrilateral containing two pairs of parallel sides.	
Rectangle 	A quadrilateral containing four right angles.	
Rhombus 	A quadrilateral containing four equal-length sides.	
Square 	A quadrilateral with four right angles and four equal-length sides.	
Trapezoid 	A quadrilateral with at least one pair of parallel sides.	

- Instruction includes providing a graphic organizer and having students use sticky notes with specific attributes on them to help them classify figures.
 - For example, students are provided with a graphic organizer like the one shown below with an example of the figure filled in for them to refer to and yellow sticky notes that have “4 equal sides” written on them. Students determine which figures contain this attribute and place the sticky note under those figures (square

and rhombus). The teacher then provides green sticky notes with “two pairs of parallel sides” written on them. Students place the sticky note under each figure that has that attribute (parallelogram, rhombus, rectangle, and square). Students would continue to add different color sticky notes with attributes that say, “One pair of parallel sides” and “four right angles”. Students are able to see that some figures have several sticky notes and which figures have the same sticky notes. Students will then name all the ways a figure can be classified based on the attributes they have.

Classifying Quadrilaterals

	Trapezoid	Parallelogram	Rhombus	Rectangle	Square
Sides					
Angles					
Picture					

Instructional Tasks

Instructional Task 1 (MTR.3.1, MTR.4.1)

Part A. Roll a number cube twice and write a statement based on the key below.

Number Cube Key

- 1 – Equilateral
- 2 – Acute
- 3 – Right
- 4 – Obtuse
- 5 – Isosceles
- 6 – Scalene

Part B. Write a statement that reads, “A(n) _____ (roll 1) triangle is _____ (always, sometimes or never) a(n) _____ triangle (roll 2).” Complete your statement by determining whether the category of triangle from roll 1 is always, sometimes, or never the category of triangle from roll 2. Complete this process three more times for a total of four statements.

Part C. Choose one of the statements that you said is sometimes true. Give an example of when the statement is true and when the statement is not true using picture models or words. If none of your statements are sometimes true, then create one to give an example.

Instructional Items

Instructional Item 1

Choose all the shapes that can **always** be classified as parallelograms.

- a. Trapezoid
- b. Rectangle
- c. Rhombus
- d. Square

e. Equilateral Triangle

**The strategies, tasks and items included in the BIG-M are examples and should not be considered comprehensive.*

MA.5.GR.1.2

Benchmark

MA.5.GR.1.2 Identify and classify three-dimensional figures into categories based on their defining attributes. Figures are limited to right pyramids, right prisms, right circular cylinders, right circular cones and spheres.

Benchmark Clarifications:

Clarification 1: Defining attributes include the number and shape of faces, number and shape of bases, whether or not there is an apex, curved or straight edges and curved surfaces or flat faces.

Connecting Benchmarks/Horizontal Alignment

- There are no direct connections outside of this standard; however, teachers are encouraged to find possible indirect connections.

Terms from the K-12 Glossary

- Cone
- Cylinders
- Edge
- Prisms
- Pyramids
- Sphere
- Vertex

Vertical Alignment

Previous Benchmarks

- MA.4.GR.1.1

Next Benchmarks

- MA.6.GR.2.4

Purpose and Instructional Strategies

The purpose of this benchmark is to begin formal categorization of three-dimensional figures based on attributes of their faces, edges and vertices. Three-dimensional figures were identified informally in Kindergarten and grade 1. The work in grade 5 prepares students for more detailed work with three-dimensional figures, including finding volumes and surface areas using formulas and nets in grade 6 (MA.6.GR.2.4).

- Instruction includes having students use language they have already learned and apply it to a larger variety of figures including prisms and pyramids with any number of sides.
- Instruction includes explaining that a cone has one flat base, a cylinder has two flat bases and a sphere does not have any flat bases, but each of these figures has a curved surface.

Common Misconceptions or Errors

- Students may believe that the orientation of a figure changes the three-dimensional shape.

Strategies to Support Tiered Instruction

- Instruction includes teacher providing a graphic organizer that contains three-dimensional figure names and definitions from the glossary. Students match images of the figures in different orientations to their definitions.
 - For example, the teacher provides students with a graphic organizer like the one shown below and a set of three-dimensional figure picture cards. Students match the image to the defining attributes listed.

Defining Attributes	A figure containing a polygonal base and triangular faces. The triangular faces have the same size and shape and they connect the sides of the base to a common point called the apex.	A figure with two parallel bases that are the same shape and size. The bases are connected by rectangular faces that are perpendicular to the bases. A box with identical polygons on each end.	A figure containing two congruent, parallel, circular bases whose edges are connected by a perpendicular curved surface.	A three-dimensional figure with a circular base and an apex that is connected to the base by a collection of line segments that form a curved surface.	A three-dimensional figure with all points equidistant from a point called the center.
Examples					

Example Figure Cards

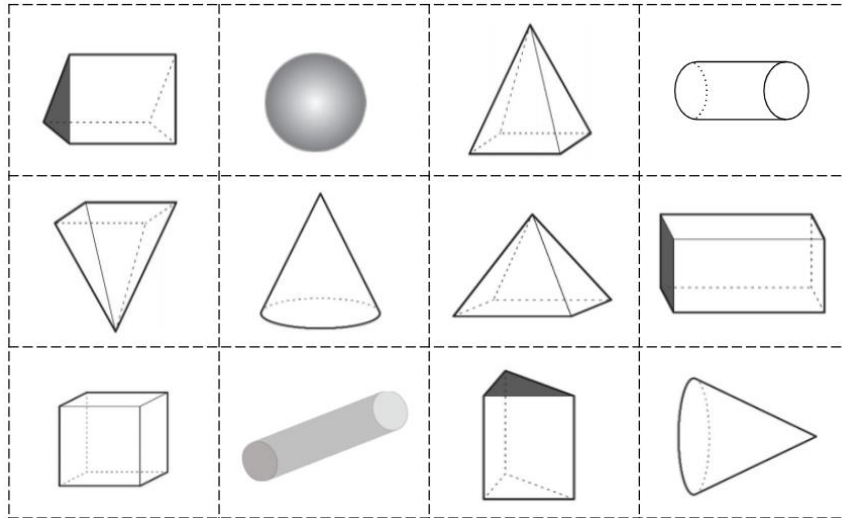

- Instruction includes providing three-dimensional figures made of plastic or wood and having students identify the shapes that make up their base or bases and faces. Students then look at the definition for each figure and classify it based on the attributes they identified.
 - For example, the teacher provides the students with a triangular prism like the one shown below. The students then identify the two bases as triangles and the faces connecting them as rectangles. The teacher provides students with the definitions for three-dimensional figures and has them determine which classification it fits in.

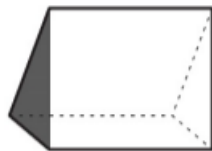

Instructional Tasks

Instructional Task 1 (MTR.4.1)

Categorize the three-dimensional figures below into the table.

Contains circular faces	Contains rectangular faces	May contain a rectangular face	Contains no faces

- Right pyramids
- Spheres
- Right circular cylinders
- Right prisms
- Right circular cones

Instructional Items

Instructional Item 1

Select all the shapes that contain an apex.

- Right pyramids
- Spheres
- Right circular cylinders
- Right prisms
- Right circular cones

**The strategies, tasks and items included in the BIG-M are examples and should not be considered comprehensive.*

MA.5.GR.2 Find the perimeter and area of rectangles with fractional or decimal side lengths.

MA.5.GR.2.1

Benchmark

MA.5.GR.2.1 Find the perimeter and area of a rectangle with fractional or decimal side lengths using visual models and formulas.

Benchmark Clarifications:

Clarification 1: Instruction includes finding the area of a rectangle with fractional side lengths by tiling it with squares having unit fraction side lengths and showing that the area is the same as would be found by multiplying the side lengths.

Clarification 2: Responses include the appropriate units in word form.

Connecting Benchmarks/Horizontal Alignment

- MA.5.NSO.2.3, MA.5.NSO.2.4, MA.5.NSO.2.5
- MA.5.FR.2.1, MA.5.FR.2.2, MA.5.FR.2.3
- MA.5.AR.1.2
- MA.5.M.1.1

Terms from the K-12 Glossary

- Area Model
- Perimeter

Vertical Alignment

Previous Benchmarks

- MA.3.GR.2.3
- MA.4.GR.2.1

Next Benchmarks

- MA.6.GR.1.3

Purpose and Instructional Strategies

The purpose of this benchmark is for students to understand how to work with fractional and decimal sums and products when calculating perimeter and area. This benchmark connects to previous work where students found areas and perimeters with whole number side lengths in grade 4 (MA.4.GR.2.1) and prepares for future work of finding area and perimeter on a coordinate plane in grade 6 (MA.6.GR.1.3).

- During instruction, teachers should encourage students to use models or drawings to assist them with finding the perimeter and area of a rectangle and have them explain how they used the model or drawing to arrive at the solution getting them to understand that multiplying fractional side lengths to find the area is the same as tiling a rectangle with unit squares of the appropriate unit fraction side lengths (*MTR.5.1*).
- This benchmark provides a natural real-world context and also a visual model for the multiplication of fractions and decimals. When finding the area, teachers can begin with students modeling multiplication with whole numbers and progress into the fractional and decimal parts, such as area models using rectangles or squares, fraction strips/bars and sets of counters.
 - For example, ask questions such as, “What does 2×3 mean?” Then, follow with questions for multiplication with fractions, such as, “What does $\frac{3}{4} \times \frac{1}{3}$ mean?” “What does $\frac{3}{4} \times 7$ mean?” (7 sets of $\frac{3}{4}$) and “What does $7 \times \frac{3}{4}$ mean?” ($\frac{3}{4}$ of a set of 7) (*MTR.2.1, MTR.3.1, MTR.5.1*).

Common Misconceptions or Errors

- Students may believe that multiplication always results in a larger number. Working with area provides them with concrete situations where this is not true.
 - For example a city block that is $\frac{1}{10}$ mile by $\frac{1}{10}$ mile has an area of $\frac{1}{100}$ of a square mile.
- Students may have difficulty connecting visual models to the symbolic representation using equations. Use concrete visuals to represent problems.

Strategies to Support Tiered Instruction

- Instruction provides opportunities to use concrete visuals to represent problems. Instruction includes providing a rectangle to divide into fractional parts. The teacher provides students with fractional dimensions to divide the figure into to find the area of part of the whole figure. Before calculating the area, students explain if the area will be greater or less than one of the dimensions and explain how they know.
 - For example, the teacher provides students with a blank rectangle and has students divide into fractional parts as shown below. The teacher uses prompts like those shown to help guide the students. After dividing the figure, the students use two different colors to shade the fractional parts and label each side with the shaded dimensions ($\frac{6}{8}$ or $\frac{4}{6}$).

Divide the figure vertically into eights.
 Divide the figure horizontally into sixths.
 Shade $\frac{6}{8}$ vertically and $\frac{4}{6}$ horizontally. The area of $\frac{6}{8} \times \frac{4}{6}$ is where the 2 shaded sections overlap.
 Is the shaded area greater or less than $\frac{6}{8}$?
 How do you know?

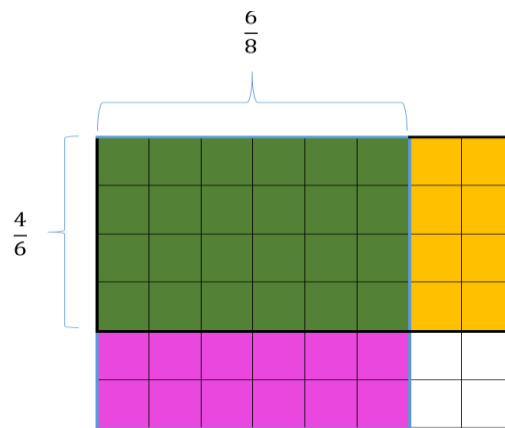

- Instruction includes providing fractional area models printed on transparency sheets. Models include equal size wholes divided into thirds, fourths, fifths, sixths, eighths, tenths, and twelfths. Students use two transparencies to show the area of given dimensions.
 - For example, the teacher asks students to find the area of a figure with side lengths of $\frac{3}{4}$ inch and $\frac{4}{10}$ inch. Students model $\frac{3}{4} \times \frac{4}{10}$ by shading $\frac{3}{4}$ of one fraction model and $\frac{4}{10}$ of another fraction model. The teacher has students explain if the area will be greater or less than $\frac{3}{4}$ and how they know. The students then overlap the two figures and determine the fractional parts that overlap as being the area.

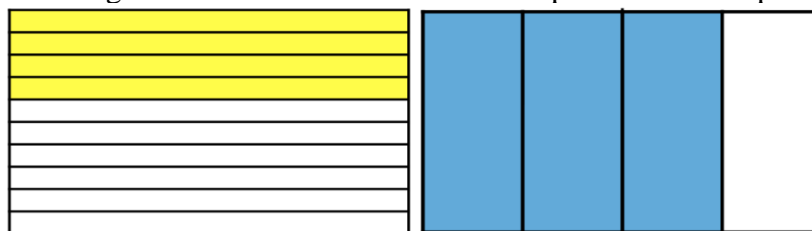
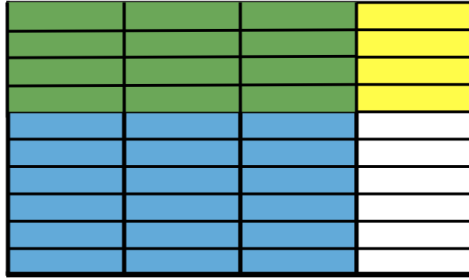

Image showing $\frac{4}{10}$ overlapping $\frac{3}{4}$, $\frac{12}{40}$ is overlapping.



Instructional Tasks

Instructional Task 1 (MTR.3.1)

Margaret draws a rectangle with a length of 5.2 inches. The width of her rectangle is one-half its length.

Part A. Draw Margaret's rectangle and show its dimensions.

Part B. What is the perimeter of her rectangle in inches?

Part C. What is the area of her rectangle in square inches?

Instructional Items

Instructional Item 1

What is the area of the square below?

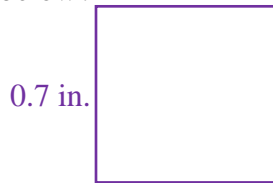

*The strategies, tasks and items included in the BIG-M are examples and should not be considered comprehensive.

MA.5.GR.3 Solve problems involving the volume of right rectangular prisms.

MA.5.GR.3.1

Benchmark

MA.5.GR.3.1 Explore volume as an attribute of three-dimensional figures by packing them with unit cubes without gaps. Find the volume of a right rectangular prism with whole-number side lengths by counting unit cubes.

Benchmark Clarifications:

Clarification 1: Instruction emphasizes the conceptual understanding that volume is an attribute that can be measured for a three-dimensional figure. The measurement unit for volume is the volume of a unit cube, which is a cube with edge length of 1 unit.

Connecting Benchmarks/Horizontal Alignment

- MA.5.NSO.2.1

Terms from the K-12 Glossary

Vertical Alignment

Previous Benchmarks

- MA.3.GR.2.1

Next Benchmarks

- MA.6.GR.2.3

Purpose and Instructional Strategies

This benchmark introduces volume to students. Their prior experiences with volume were restricted to liquid volume (also called capacity). The concept of volume should be extended from the understanding of area starting in Grade 3 (MA.3.GR.2.1), with the idea that a layer (such as the bottom of cube) can be built up by adding more layers of unit cubes. In Grade 6, (MA.6.GR.2.3) students solve volume problems involving rectangular prisms with fraction and decimal side lengths.

- As students develop their understanding of volume, they recognize that a 1-unit by 1-unit by 1-unit cube is the standard unit for measuring volume. This cube has a length of 1 unit, a width of 1 unit and a height of 1 unit and is called a cubic unit. This cubic unit is written with an exponent of 3 (e.g., in^3 , 3^3). Students connect this notation to their understanding of powers of 10 in our place value system (*MTR.5.1*).

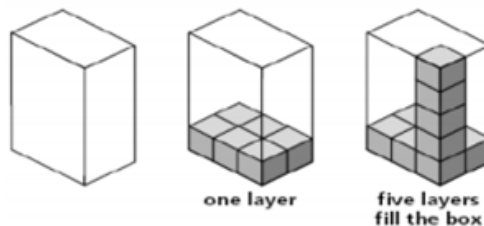

Common Misconceptions or Errors

- Students may incorrectly fill figures to find volume with cubes. Students need to ensure there is no empty space included and that unit cubes are equally-sized and packed tightly in without overlaps.

Strategies to Support Tiered Instruction

- Instruction includes providing unit cubes and having students build rectangular prisms with specific dimensions and then calculating the volume.

-
- For example, the teacher provides students with unit cubes and the following dimensions: length is 8 units, width is 4 units, and height is 5 units. Students stack equally sized unit cubes and ensure that the cubes are packed tightly with no gaps or overlaps to create a solid three-dimensional figure. Students begin building the figure as shown below, continuing to fill it in until complete. Students calculate the volume by multiplying $8 \times 4 \times 5$ and then decompose the figure and count the cubes to determine if their calculation is correct.

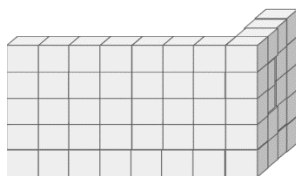

- Instruction includes providing rectangular prisms filled with cubes. Some are filled correctly with no gaps or overlaps, and others have the cubes filling the rectangular prism, but with gaps left between them. Students identify which are stacked correctly to find volume and which are not stacked correctly and record the dimensions of the number of cubes for the height, length, and width, counting the total to determine the volume.

Instructional Tasks

Instructional Task 1 (MTR.6.1)

Molly is putting her cube-shaped blocks into their storage container after she finishes playing with her sister. The storage container is shaped like a right rectangular prism and she has a total of 120 blocks. The bottom layer of her storage container holds exactly 6 rows of 4 blocks each with no gaps or overlaps. The storage container holds exactly 6 layers of blocks with no gaps or overlaps.

Part A. Will all of Molly's blocks fit in the storage container? Explain how you know using drawings and equations.

Part B. If there is enough room, determine how many more blocks Molly could fit in the storage container. If there is not enough room, determine how many blocks will not fit be able to fit in the storage container.

Instructional Items

Instructional Item 1

What is the volume of the right rectangular prism?

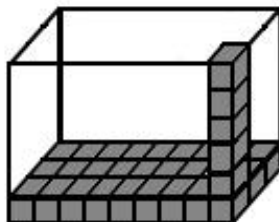

**The strategies, tasks and items included in the BIG-M are examples and should not be considered comprehensive.*
MA.5.GR.3.2

Benchmark

MA.5.GR.3.2 Find the volume of a right rectangular prism with whole-number side lengths using a visual model and a formula.

Benchmark Clarifications:

Clarification 1: Instruction includes finding the volume of right rectangular prisms by packing the figure with unit cubes, using a visual model or applying a multiplication formula.

Clarification 2: Right rectangular prisms cannot exceed two-digit edge lengths and responses include the appropriate units in word form.

■ Connecting Benchmarks/Horizontal Alignment

- MA.5.NSO.2.1

■ Terms from the K-12 Glossary

- Rectangular Prism

■ Vertical Alignment

Previous Benchmarks

- MA.3.GR.2.2

Next Benchmarks

- MA.6.GR.2.3

■ Purpose and Instructional Strategies

The purpose of this benchmark is for students to make connections between packing a right rectangular prism with unit cubes to determine its volume and developing and applying a multiplication formula to calculate it more efficiently. Students have developed experience with area since grade 3 (MA.3.GR.2.2). For volume, side lengths are limited to whole numbers in grade 5, and problems extend to fraction and decimal side lengths in grade 6 (MA.6.GR.2.3).

- Instruction should make connections between the exploration expected of MA.5.GR.3.1 and what is happening mathematically when calculating volume (*MTR.2.1*).
- Instruction should begin by connecting the measurement of a right rectangular prism to the calculation of a rectangle's area. The bottom layer of the prism is packed with a number of rows with a number of cubes in each, like area of a rectangle is calculated with unit squares. From there, the third dimension (height) of the prism is calculated by the number of layers stacked atop one another.
- Having students explore how volume is calculated helps students see the patterns and develop a multiplication formula that will help them make sense of the two most common volume formulas, $V = B \times h$ (where B represents the area of the rectangular prism's base) and $V = l \times w \times h$. If students understand conceptually what the formulas mean, they are more likely to use them effectively and efficiently (*MTR.5.1*).
- When students use a multiplication formula, it is important for them to see that it is a matter of choice which dimensions of rectangular prisms are named length, width and height. This will help students understand that when calculating the volume of a rectangular prism, the three dimensions are multiplied together and that the order of factors does not matter (commutative property of multiplication).

■ Common Misconceptions or Errors

- Students may confuse the difference between b in the area formula $A = b \times h$ and B in the volume formula $V = B \times h$. When building understanding of the volume formula for right rectangular prisms, teachers and students should include a visual model to justify their calculations.
- Students may make computational errors when calculating volume. Encourage them to estimate reasonable solutions before calculating and justify their solutions after. Instruction can also encourage students to find efficient ways to use the formula.
 - For example, when calculating the volume of a rectangular prism using the formula $V = 45 \times 12 \times 2$, students may find calculating easier if they multiply 45×2 (90) first, instead of 45×12 . During class discussions, teachers should encourage students to share their strategies so they can build efficiency.

Strategies to Support Tiered Instruction

- Instruction includes the use of visual models to justify calculations when using the volume formula for right rectangular prisms.
- Instruction includes differentiating between base in the area formula, $Area = b \times h$ and base in the volume formula $Volume = B \times h$. Teacher provides students with models of two-dimensional figures, and three-dimensional figures, and has them identify which formula they will use and what the base in each image is.
 - For example, the students highlight the lines included in the base measurement for each figure. Then, they use the base to calculate the area or volume. The teacher provides students with a set of models like the one shown below asking which image they would use the area formula for and which image they would use the volume formula for. Students then highlight the measurements used for the base in the formula. For the first figure, students would use volume and the formula $B \times h$ with $B = 16 \times 4$. For the second figure, students would find area and use the formula $b \times h$ with $b = 16$.

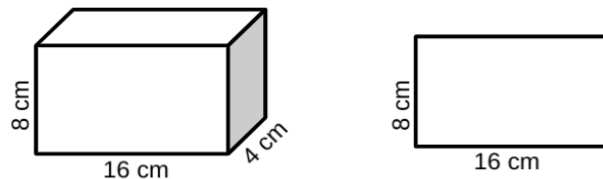

- Instruction includes providing models of two-dimensional and three-dimensional figures with the area and volume formula labeled and color-coded with the measurements.
 - For example, the teacher provides students with the following set of visual models and has students explain the difference in the base measurement in each formula. Students calculate the area or volume of each figure using the formula.

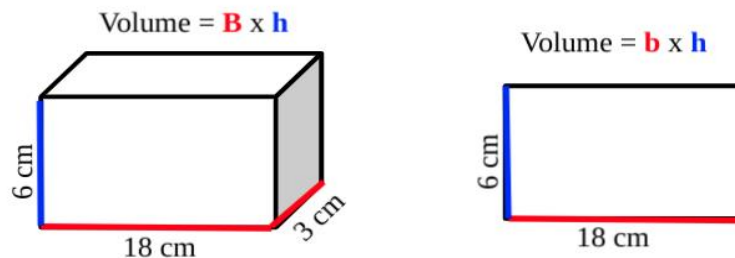

- Instruction includes providing a graphic organizer that requires students to estimate the volume of real-world examples provided and then solve using any strategy they would like.
 - For example, the teacher provides students with a graphic organizer similar to the one shown below. Students use it to find the volume of the given example and then compare their strategy to others.

<p style="text-align: center;">Situation</p> <p>The class filled their aquarium to the top with water. The aquarium is shown below. Find the volume to determine how much water it can hold.</p> 	<p style="text-align: center;">Estimate the Volume</p>
<p style="text-align: center;">Solve Using Any Strategy</p>	<p style="text-align: center;">Compare your strategy to another strategy used in class.</p> <p>How are the two strategies similar?</p> <p>How are the two strategies different?</p> <p>Which strategy do you think is more efficient and why?</p>

- Instruction includes finding efficient ways to use the formula.
 - For example, when calculating the volume of a rectangular prism using the formula $V = 45 \times 12 \times 2$, students may find calculating easier if they multiply 45×2 (which equals 90) first, instead of 45×12 . During class discussions, teachers should encourage students to share their strategies so they can build efficiency.
- Instruction includes providing worked examples of volume and having students determine which strategy is the better strategy to use and why.
 - For example, the teacher provides students with the following image and two examples of how students solved for volume. Student A solved the area of the base first using the Distributive Property to help with the multiplication. Student B used the Associative Property of Multiplication and multiplied 20×5 first. Students discuss both strategies and explain which would be easier and why.

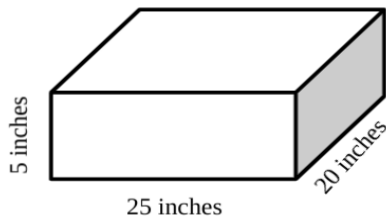

Student A	Student B
<p style="text-align: center;">Volume = B x h</p> <p style="text-align: center;">(25 x 20) x 5</p> <p style="text-align: center;">[(25 x 10) + (25 x 10)] x 5</p> <p style="text-align: center;">(250 + 250) x 5</p> <p style="text-align: center;">500 x 5 = 2,500</p>	<p style="text-align: center;">Volume = B x h</p> <p style="text-align: center;">(25 x 20) x 5</p> <p style="text-align: center;">25 x (20 x 5)</p> <p style="text-align: center;">25 x 100</p> <p style="text-align: center;">2,500</p>

Instructional Tasks

Instructional Task 1 (MTR.2.1)

The Great Graham Cracker Company is looking for a new package design for next year's boxes. The boxes must be a right rectangular prism and measure 144 cubic centimeters.

Part A. What are three package designs the company could use? Draw models and write equations to show their volumes.

Part B. Dr. Cruz, the company's founder, wants the height of the package to be exactly 8 centimeters. What are two package designs that the company can use? Draw models and write equations to show their volumes.

Instructional Items

Instructional Item 1

Which of the following equations can be used to calculate the volume of the rectangular prism below?

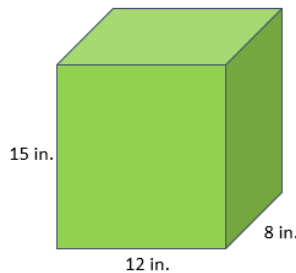

- a. $V = 96 \times 15$
- b. $V = 15 \times 8 \times 12$
- c. $V = 15 \times 20$
- d. $V = 27 \times 8$
- e. $V = 23 \times 12$

Instructional Item 2

A bedroom shaped like a rectangular prism is 15 feet wide, 32 feet long and measures 10 feet from the floor to the ceiling. What is the volume of the room?

- a. 57 cubic ft.
- b. 150 cubic ft.
- c. 4,500 cubic ft.
- d. 4,800 cubic ft.

**The strategies, tasks and items included in the BIG-M are examples and should not be considered comprehensive.*

Benchmark

MA.5.GR.3.3

Solve real-world problems involving the volume of right rectangular prisms, including problems with an unknown edge length, with whole-number edge lengths using a visual model or a formula. Write an equation with a variable for the unknown to represent the problem.

Example: A hydroponic box, which is a rectangular prism, is used to grow a garden in wastewater rather than soil. It has a base of 2 feet by 3 feet. If the volume of the box is 12 cubic feet, what would be the depth of the box?

Benchmark Clarifications:

Clarification 1: Instruction progresses from right rectangular prisms to composite figures composed of right rectangular prisms.

Clarification 2: When finding the volume of composite figures composed of right rectangular prisms, recognize volume as additive by adding the volume of non-overlapping parts.

Clarification 3: Responses include the appropriate units in word form.

Connecting Benchmarks/Horizontal Alignment

- MA.5.NSO.2.1/2.2
- MA.5.FR.1.1
- MA.5.AR.1.1
- MA.5.M.1.1

Terms from the K-12 Glossary

- Composite Figure
- Rectangular Prism

Vertical Alignment

Previous Benchmarks

- MA.4.GR.2.1

Next Benchmarks

- MA.6.GR.2.3

Purpose and Instructional Strategies

The purpose of this benchmark is to solve real-world problems involving right rectangular prisms using a visual model or a formula. The real-world problems can require students to find an unknown side length or find the volume of a composite figure (*MTR.7.1*), if the figure can be decomposed into smaller right rectangular prisms. Students are expected to write an equation with a variable for the unknown to represent the problem. Similar expectations for area were developed in grade 4 (*MA.4.GR.2.1*) and this work will be extended to include fraction and decimal side lengths in grade 6 (*MA.6.GR.2.3*).

- Instruction of this benchmark can be combined with *MA.5.GR.3.2* as students develop and apply understanding of calculating volume of right rectangular prisms using visual models and formulas (*MTR.2.1*).
- While finding volume, teachers should have students communicate and justify their decisions while solving problems (*MTR.4.1*).
- Instruction includes problems with the unknown side length being a fraction (*MA.5.FR.1.1*).
 - For example, if a box has a base of $5\text{ in} \times 3\text{ in}$, and a volume of 20 in^3 , what is the length of its missing side?
- During instruction teachers should allow students the flexibility to use different equations for the same problem.
 - For example, to find the height of a rectangular prism with volume 120 and base dimensions 3 and 10, students can use the any of the follow equations: $120 =$

$$3 \times 10 \times h \text{ or } 120 = 30h \text{ or } 120 \div 30 = h.$$

Common Misconceptions or Errors

- Students may confuse the difference between b in the area formula $A = b \times h$ and B in the volume formula $V = B \times h$. When building understanding of the volume formula for right rectangular prisms, teachers and students should include a visual model to use to justify their calculations.
- Students may make computational errors when calculating volume. Encourage them to estimate reasonable solutions before calculating and justify their solutions after. Instruction can also encourage students to find efficient ways to use the formula.
 - For example, when calculating the volume of a rectangular prism using the formula, $V = 45 \times 12 \times 2$, students may find calculating easier if they first multiply 45×2 (which equals 90), instead of 45×12 . During class discussions, teachers should encourage students to share their strategies so they can build efficiency.

Strategies to Support Tiered Instruction

- Instruction includes the use of visual models to justify calculations when using the volume formula for right rectangular prisms.
- Instruction includes differentiating between base in the area formula, $Area = b \times h$ and base in the volume formula, $Volume = B \times h$. Teacher provides students with models of two-dimensional figures, and three-dimensional figures, and has them identify which formula they will use and what the base in each image is. Students highlight the lines included in the base measurement for each figure and use the base to calculate the area or volume.
 - For example, the teacher provides students with a set of models like the one shown below. The teacher asks students which image they would use the area formula for and which image they would use the volume formula for. Students then highlight the measurements used for the base in the formula. For the first figure, students would use volume and the formula $B \times h$ with $B = 16 \times 4$. For the second figure, students would find area and use the formula $b \times h$ with $b = 16$.

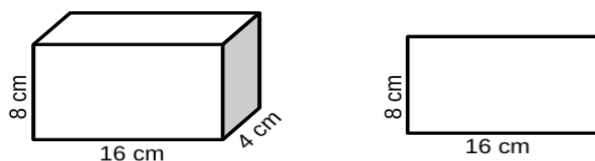

- Instruction includes providing models of two-dimensional and three-dimensional figures with the area and volume formula labeled and color-coded with the measurements.
 - For example, the teacher provides students with the following set of models and has students explain the difference in the base measurement in each formula. Students calculate the area or volume of each figure using the formula.

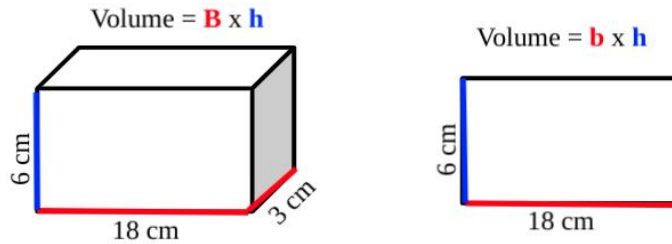

- Instruction includes providing a graphic organizer that requires students to estimate the volume of real-world examples provided and then solve using any strategy they would like. Students then compare their strategy to the strategies used by other students.
 - For example, the teacher provides students with a graphic organizer similar to the one shown below. Students use it to find the volume of the given example and then compare their strategy to others.

<p style="text-align: center;">Situation</p> <p><i>The class filled their aquarium to the top with water. The aquarium is shown below. Find the volume to determine how much water it can hold.</i></p> <div style="text-align: center;">  </div>	<p>Estimate the Volume</p>
<p>Solve Using Any Strategy</p>	<p>Compare your strategy to another strategy used in class.</p> <p>How are the two strategies similar?</p> <p>How are the two strategies different?</p> <p>Which strategy do you think is more efficient and why?</p>

- Instruction includes estimating reasonable solutions before calculating and justifying solutions after. Instruction can also encourage students to find efficient ways to use the formula.
 - For example, when calculating the volume of a rectangular prism using the formula, $V = 45 \times 12 \times 2$, students may find calculating easier if they first multiply 45×2 (which equals 90), instead of 45×12 . During class discussions, teachers should encourage students to share their strategies so they can build efficiency
- Instruction includes providing worked examples of volume and having students determine which strategy is the better strategy to use and why.
 - For example, the teacher provides students with the following image and two examples of how students solved for volume. Student A solved the area of the base first using the Distributive Property to help with the multiplication. Student B used the Associative Property of Multiplication and multiplied 20×5 first. Students discuss both strategies and explain which would be easier and why.

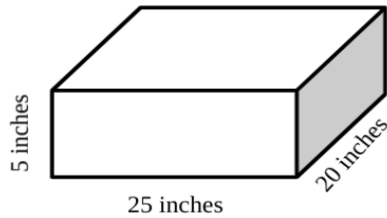

Student A	Student B
Volume = B x h	Volume = B x h
$(25 \times 20) \times 5$ $[(25 \times 10) + (25 \times 10)] \times 5$ $(250 + 250) \times 5$ $500 \times 5 = 2,500$	$(25 \times 20) \times 5$ $25 \times (20 \times 5)$ 25×100 $2,500$

Instructional Tasks

Instructional Task 1 (MTR.6.1)

The Great Graham Cracker Company places packages of their graham crackers into a larger box for shipping to area grocery stores. Each package of graham crackers is a right rectangular prism that measures 18 cubic inches. The base of each package of graham crackers measures 2 inches by 3 inches. Packages are placed upright into the shipping box.

Part A. If the larger shipping box is a cube with edges that are each 30 inches, how many layers of graham cracker packages can the shipping box hold? Show your thinking using a visual model and equation(s).

Part B. Will the packages reach the top of the shipping box? If not, what will be the length of the gap from the top of the package to the top of the shipping box?

Part C. How many graham cracker packages will fit in the shipping box?

Instructional Items

Instructional Item 1

Select all of the following that could be the dimensions of the base of a rectangular box with height of 16in and volume of 128in^3 .

- $2\text{in} \times 4\text{in}$
- $3\text{in} \times 3\text{in}$
- $1\text{in} \times 8\text{in}$
- $4\text{in} \times 2\text{in}$
- $56\text{in} \times 56\text{in}$

**The strategies, tasks and items included in the BIG-M are examples and should not be considered comprehensive.*

MA.5.GR.4 Plot points and represent problems on the coordinate plane.

MA.5.GR.4.1

Benchmark

MA.5.GR.4.1 Identify the origin and axes in the coordinate system. Plot and label ordered pairs in the first quadrant of the coordinate plane.

Benchmark Clarifications:

Clarification 1: Instruction includes the connection between two-column tables and coordinates on a coordinate plane.

Clarification 2: Instruction focuses on the connection of the number line to the x - and y -axis.

Clarification 3: Coordinate planes include axes scaled by whole numbers. Ordered pairs contain only whole numbers.

Connecting Benchmarks/Horizontal Alignment

- MA.5.AR.3.2
- MA.5.DP.1.1

Terms from the K-12 Glossary

- Coordinate Plane (first quadrant)
- Origin
- x -axis
- y -axis

Vertical Alignment

Previous Benchmarks

- MA.4.NSO.1.3

Next Benchmarks

- MA.6.GR.1

Purpose and Instructional Strategies

The purpose of this benchmark is for students to extend their thinking from grade 4 (MA.4.NSO.1.3) about horizontal and vertical number lines to plot and label whole number ordered pairs on a coordinate plane. In addition, students will make a connection between a two-column table and the ordered pairs represented on the coordinate plane. In grade 6 (MA.6.GR.1.1), students plot rational number pairs in all four quadrants of the coordinate plane.

- During instruction, teachers should relate the coordinate plane as the intersection of two axes – a horizontal number line called the x -axis and a vertical number line called the y -axis. The number lines that form the axes are perpendicular and meet at the origin, labeled by the ordered pair $(0, 0)$ (*MTR.5.1*).
- When students learn to plot ordered pairs represented in a two-column table, they should understand that the ordered pair (x, y) represents how far to travel from the origin along the x - and y -axes.
 - For example, students should understand that in the ordered pair $(2, 4)$, the point travels along the x -axis 2 whole units to the right, and then vertically (parallel to the y -axis) 4 units up (*MTR.5.1*).

Common Misconceptions or Errors

- Students can confuse the x - and y -values in an ordered pair and move vertically along the y -axis before moving horizontally along the x -axis.
 - For example, they may mean to plot and label the ordered pair $(2, 4)$, but plot and label $(4, 2)$ instead. To assist students with this misconception, have students practice with creating directions for their student peers to follow to allow them to gain a better understanding of the direction and distance on the coordinate plane.
- Some students may not understand what an x - or y -coordinate value of 0 represents. During instruction, students should justify why ordered pairs with a 0 will plot on the x -axis or y -axis.

Strategies to Support Tiered Instruction

- Instruction includes the teacher providing coordinate points to graph in quadrant 1 of the coordinate plane along with two small objects. The students explain how they move the object along the x -axis and then up the y -axis to the location provided. The teacher then provides the points reversed to graph and has students explain the difference in how they move the second object compared to the first.
 - For example, the teacher provides students with a coordinate plane like the one shown below. The teacher provides a set of coordinate points such as $(8,2)$. Students take turns moving an object, such as a two-colored counter, and explain the location of the point using the x - and y -axis in their explanation. The teacher then provides the points in reverse, $(2,8)$. The next student will move a second object and explain the location of the point as well as the difference between the two locations.

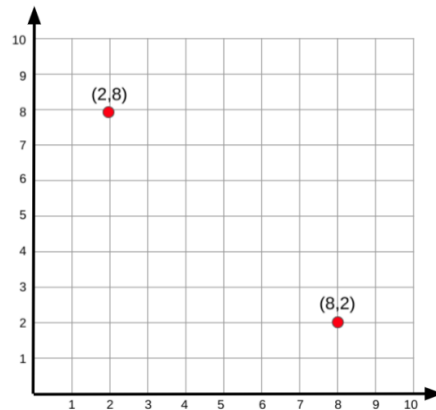

- Instruction includes the teacher providing a set of cards that have coordinate points on them, some with 0 as the location on the x -axis, some with 0 as the location on the y -axis, others with no 0 in the coordinates. Students sort the cards into three categories: points located on the x -axis, points located on the y -axis and neither. Students will justify their reasoning by explaining how the 0, or lack of a 0, in each set of points helped them.
 - For example, the teacher provides cards with the following points on them:
 $(2,5)$, $(0,8)$, $(3,0)$, $(2,0)$, $(1,9)$, $(0,4)$, $(6,0)$, $(7,2)$, $(9,0)$, $(0,5)$
Students sort the points into three categories as shown below.

**Points located on the
 x -axis.**

**Points located on the
 y -axis.**

**Points not located on
either axis.**

(3,0)	(0,8)	(2,5)
(2,0)	(0,4)	(1,9)
(6,0)	(0,5)	(7,2)
(9,0)		

- Instruction includes the teacher creating a giant coordinate plane on the floor with painters' tape or outside with sidewalk chalk. The teacher or a student will then create directions for their peers to follow. The teacher or student will provide a set of coordinate points, including those with 0 as the x - or y -coordinate. Another student will physically move to the location, describing as they move, which axis they are moving on and counting the spaces until they reach their final location.
 - For example, the teacher or a student tells a student to move to the location of (4,6) on the coordinate plane. The student says, "I begin at the origin which is (0,0) and move 1, 2, 3, 4 spaces to the right on the x -axis. I then move 1, 2, 3, 4, 5, 6 spaces up on the y -axis to my final location of (4,6)."
 - For example: The teacher provides a student with the location (5,0). The student will move along the x -axis 5 spaces and stop. The teacher provides another student with the location (0,5). That student moves up the y -axis 5 spaces and stop. The teacher will then have the students explain how their location ended up on the x - or y -axis as well as the relationship between those located on the y -axis and those located on the x -axis.

Instructional Tasks

Instructional Task 1 (MTR.3.1)

Part A. A point has coordinates (3, 5). If you were to graph this point on a coordinate plane, what does the 3 tell you to do?

Part B. Consider the same point with coordinates (3, 5). What does the 5 tell you to do?

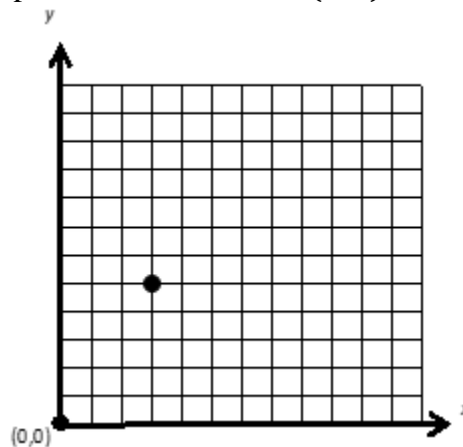

Part C. The point above has coordinates (3, 5). Which of these is the x -coordinate? Which of these is the y -coordinate?

Instructional Items

Instructional Item 1

What ordered pair represents the origin of a coordinate plane?

- a. (0, 0)
- b. (1, 0)
- c. (0, 1)
- d. (1, 1)

Instructional Item 2

A point has coordinates (1, 6). If you were to plot this point on a coordinate plane, what does the 1 tell you to do?

- a. From the origin, move along the x -axis 1 unit up.
- b. From the origin, move along the y -axis 1 unit up.
- c. From the origin, move along the x -axis 1 unit right.
- d. From the origin, move along the y -axis 1 unit right.

**The strategies, tasks and items included in the BIG-M are examples and should not be considered comprehensive.*

MA.5.GR.4.2

Benchmark

MA.5.GR.4.2 Represent mathematical and real-world problems by plotting points in the first quadrant of the coordinate plane and interpret coordinate values of points in the context of the situation.

Example: For Kevin's science fair project, he is growing plants with different soils. He plotted the point (5, 7) for one of his plants to indicate that the plant grew 7 inches by the end of week 5.

Benchmark Clarifications:

Clarification 1: Coordinate planes include axes scaled by whole numbers. Ordered pairs contain only whole numbers.

Connecting Benchmarks/Horizontal Alignment

- MA.5.AR.1.1
- MA.5.AR.3.2
- MA.5.DP.1.1

Terms from the K-12 Glossary

- Coordinate Plane (first quadrant)
- Origin
- x -axis
- y -axis

Vertical Alignment

Previous Benchmarks

- MA.4.NSO.1.3

Next Benchmarks

- MA.6.GR.1

Purpose and Instructional Strategies

The purpose of this benchmark is for students to interpret coordinate values plotted in mathematical and real-world contexts. Students have been plotting and interpreting numbers on a number line since Kindergarten. Students' first experience with interpreting points plotted on a coordinate plane is in grade 5, which leads to the foundational understanding needed throughout middle school.

- An example of interpreting coordinate values of points in a mathematical context could be identifying points of a rectangle plotted on the coordinate plane.
- An example of interpreting coordinate values of points in a real-world context could look like the example in the benchmark description. In this real-world example, students would interpret that each axis represents a variable describing a situation. The x -axis represents number of weeks and the y -axis represents plants' heights in inches.
- During instruction, teachers should provide plenty of opportunities for students to both plot and interpret ordered pairs on a coordinate plane. Teachers should connect the expectations of this benchmark with MA.5.GR.4.1 by having students represent the points plotted on two-column tables as well (*MTR.4.1*, *MTR.7.1*).
- In real-world contexts teachers should allow students the flexibility to decide which variable is represented by x and which is represented by y . Students may be encouraged to explain their preference.
- During instruction, students should be given the flexibility to decide how to scale their graphs for a given real-world context. Students may be encouraged to explain their preference.

Common Misconceptions or Errors

- Students can confuse the x - and y -values in an ordered pair and move vertically along the y -axis before moving horizontally along the x -axis.
 - For example, they may mean to plot and label the ordered pair $(2, 4)$, but plot and label $(4, 2)$ instead.
- Some students may not understand what an x - or y -coordinate value of 0 represents. During instruction, students should justify why ordered pairs with a 0 will plot on the x -axis or y -axis.

Strategies to Support Tiered Instruction

- Instruction includes the teacher providing coordinate points to graph in quadrant 1 of the coordinate plane along with two small objects. The students explain how they move the object along the x -axis and then up the y -axis to the location provided. The teacher then provides the points reversed to graph and has students explain the difference in how they move the second object compared to the first.
 - For example, the teacher may provide students with a coordinate plane like the one shown below. The teacher provides a set of coordinate points such as $(8, 2)$. Students take turns moving an object, such as a two-colored counter, and explain the location of the point using the x - and y -axis in their explanation. The teacher will then provide the points in reverse, $(2, 8)$. Students will move a second object and explain the location of the point as well as the difference between the two locations.

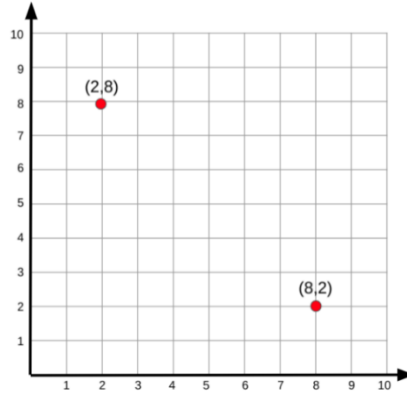

- Instruction includes the teacher providing a set of cards that have coordinate points on them, some with 0 as the location on the x -axis, some with 0 as the location on the y -axis, others with no 0 in the coordinates. Students sort the cards into three categories: points located on the x -axis, points located on the y -axis and neither. Students justify their reasoning by explaining how the 0, or lack of a 0, in each set of points helped them.
 - For example, the teacher provides cards with the following points on them: $(2,5)$, $(0,8)$, $(3,0)$, $(2,0)$, $(1,9)$, $(0,4)$, $(6,0)$, $(7,2)$, $(9,0)$, $(0,5)$
Students sort the points into three categories as shown below.

Points located on the x -axis.	Points located on the y -axis.	Points not located on either axis.
$(3,0)$	$(0,8)$	$(2,5)$
$(2,0)$	$(0,4)$	$(1,9)$
$(6,0)$	$(0,5)$	$(7,2)$
$(9,0)$		

- Instruction includes the teacher creating a giant coordinate plane on the floor with painters' tape or outside with sidewalk chalk. The teacher or a student will then create directions for their peers to follow. The teacher or student provides a set of coordinate points, including those with 0 as the x - or y -coordinate. Another student physically moves to the location, describing as they move, which axis they are moving on and counting the spaces until they reach their final location.
 - For example, the teacher or a student tells another student to move to the location of $(4,6)$ on the coordinate plane. The student says, "I begin at the origin which is $(0,0)$ and move 1, 2, 3, 4 spaces to the right on the x -axis. I then move 1, 2, 3, 4, 5, 6 spaces up on the y -axis to my final location of $(4,6)$."
 - For example, the teacher provides a student with the location $(5,0)$. The student moves along the x -axis 5 spaces and stop. The teacher provides another student with the location $(0,5)$. That student moves up the y -axis 5 spaces and stop. The teacher then has students explain how their location ended up on the x - or y -axis as well as the relationship between those located on the y -axis and those located on the x -axis.

Instructional Tasks

Instructional Task 1 (MTR.7.1)

Lukas can make four bracelets per hour and he will work for five hours. Make a two-column table where the first column contains the numbers 1, 2, 3, 4, 5 indicating the number of hours

worked, and the second column shows how many total bracelets he has made in that many hours.

Plot points on the coordinate plane to represent your table, where the x -coordinate represents the number of hours worked and the y -coordinate represents the number of bracelets made.

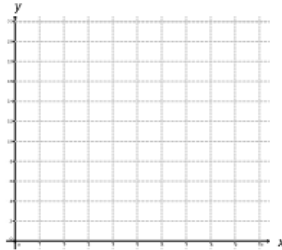

Instructional Items

Instructional Item 1

The map below shows the location of several places in a town.

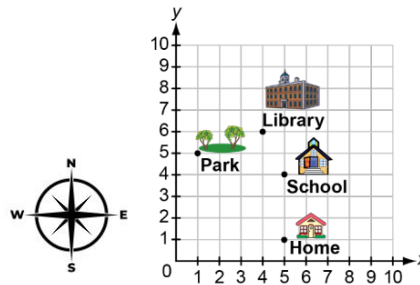

The fire department is 2 blocks north of the library. What ordered pair represents the location of the fire department?

- a. (4, 2)
- b. (2, 4)
- c. (4, 8)
- d. (8, 4)

Instructional Item 2

Deanna is plotting a square on the coordinate plane below.

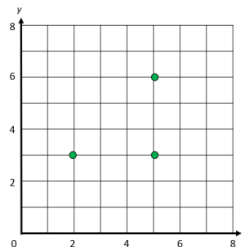

What ordered pair would represent the fourth vertex?

- a. (6, 2)
- b. (2, 6)
- c. (2, 0)
- d. (0, 2)

**The strategies, tasks and items included in the BIG-M are examples and should not be considered comprehensive.*

Data Analysis & Probability

MA.5.DP.1 *Collect, represent and interpret data and find the mean, mode, median or range of a data set.*

MA.5.DP.1.1

Benchmark

MA.5.DP.1.1

Collect and represent numerical data, including fractional and decimal values, using tables, line graphs or line plots.

Example: Gloria is keeping track of her money every week. She starts with \$10.00, after one week she has \$7.50, after two weeks she has \$12.00 and after three weeks she has \$6.25. Represent the amount of money she has using a line graph.

Benchmark Clarifications:

Clarification 1: Within this benchmark, the expectation is for an estimation of fractional and decimal heights on line graphs.

Clarification 2: Decimal values are limited to hundredths. Denominators are limited to 1, 2, 3 and 4. Fractions can be greater than one.

Connecting Benchmarks/Horizontal Alignment

- MA.5.NSO.1.4
- MA.5.AR.1.2
- MA.5.GR.4.1, MA.5.GR.4.2

Terms from the K-12 Glossary

- Line Graphs
- Line Plots

Vertical Alignment

Previous Benchmarks

- MA.4.DP.1.1

Next Benchmarks

- MA.6.DP.1.5

Purpose and Instructional Strategies

The purpose of this benchmark is to collect and display authentic numerical data in tables, line graphs or line plots, including fractional and decimal values. Students have represented whole number and fractional values using tables, stem-and-leaf plots and line plots in grade 4 (MA.4.DP.1.1). In grade 6, this work will extend to box plots and histograms (MA.6.DP.1.5).

- Instruction with line graphs should develop the understanding that values in this graph often represent data that changes over time.
- Instruction should include identifying the meaning of the points presented on the x -axis and y -axis with both axes being labeled correctly.

Common Misconceptions or Errors

- For line plots, students may misread a number line and have difficulty because they use whole-number names when counting fractional parts on a number line instead of the fraction name.

Strategies to Support Tiered Instruction

- Instruction includes opportunities to use concrete models and draw number lines to connect learning with fraction understanding. Students plot fourths on the number line, paying particular attention to what each tick mark and the “distance” between each tick mark represents.
 - Example:



- For example, utilizing fraction strips or tiles, students will be able to connect fractional parts to the measurement on a number line.

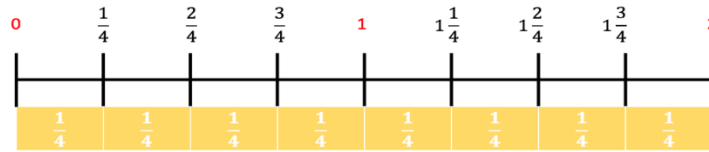

Instructional Tasks

Instructional Task 1 (MTR.3.1)

Claire studied the amount of water in different glasses. The data she collected is below. Use her data to create a line plot to show the amount of water in the glasses.

Amount of Water in a Glass (cups)									
$\frac{1}{2}$	$\frac{1}{4}$	$\frac{1}{3}$	$\frac{1}{4}$	$\frac{1}{4}$	$\frac{5}{4}$	$\frac{3}{2}$	$\frac{5}{2}$	$\frac{1}{4}$	$\frac{1}{3}$

Instructional Items

Instructional Item 1

A line graph is shown.

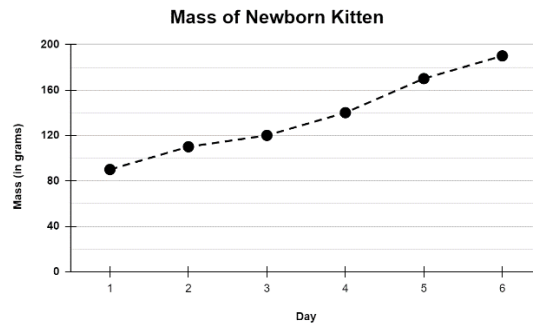

- Part A. What is the approximate change in the kitten’s mass, in grams, between Days 3 and 4?
- Part B. What is the approximate change in the kitten’s mass, in grams, between Days 2 and 5?

*The strategies, tasks and items included in the BIG-M are examples and should not be considered comprehensive.

MA.5.DP.1.2

Benchmark

MA.5.DP.1.2 Interpret numerical data, with whole-number values, represented with tables or line plots by determining the mean, mode, median or range.

Example: Rain was collected and measured daily to the nearest inch for the past week. The recorded amounts are 1, 0, 3, 1, 0, 0 and 1. The range is 3 inches, the modes are 0 and 1 inches, and the mean value can be determined as $\frac{(1+0+3+1+0+0+1)}{7}$, which is equivalent to $\frac{6}{7}$ of an inch. This mean would be the same if it rained $\frac{6}{7}$ of an inch each day.

Benchmark Clarifications:

Clarification 1: Instruction includes interpreting the mean in real-world problems as a leveling out, a balance point or an equal share.

Connecting Benchmarks/Horizontal Alignment

- MA.5.FR.1.1
- MA.5.AR.1.1

Terms from the K-12 Glossary

- Line Plots
- Mean
- Median
- Mode
- Range

Vertical Alignment

Previous Benchmarks

- MA.4.DP.1.2

Next Benchmarks

- MA.6.DP.1.2, MA.6.DP.1.6

Purpose and Instructional Strategies

The purpose of this benchmark is to interpret numerical data by using the mean, mode, median and range. This work builds on the previous understanding of mode, median, and range in Grade 4 (MA.4.DP.1.2). In Grade 6, a focus will be on comparing the advantages and disadvantages of the mean and median.

- When finding median and mode, it is important for students to organize their data, putting it in order from least to greatest.
- With the data organized, students can determine:
 - range by subtracting the least value from the greatest value in the set.
 - mode by finding the value that occurs most often.
 - median by finding the value in middle of the set.
 - mean by finding the average of the set of numbers.

Common Misconceptions or Errors

- Students may confuse the mean and median of a data set. During instruction, teachers should provide students with examples where the median and mean of a data set are not close in value.

Strategies to Support Tiered Instruction

- Instruction includes examples where the mean and the median are not close in value and uses a data set to explain the difference between mean and median.
 - For example, the data set shown has a median of 4 and a mean of 7. The teacher uses the data to model how the mean is calculated and how the median is found.

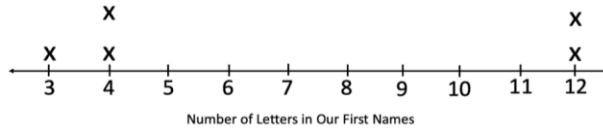

- Instruction includes writing the data on index cards or sticky notes. Students can then easily arrange the data in order from least to greatest. This will assist in finding the median of the data set.
 - For example, students use the data shown to explain the difference between mean (which is 7) and median (which is 4) and to model how the mean is calculated and how the median is found.



Instructional Tasks

Instructional Task 1 (MTR.7.1)

Bobbie is a fifth grader who competes in the 100-meter hurdles. In her 8 track meets during the season, she recorded the following times to the nearest second.

Track Meet	100-meter hurdle Time (seconds)
1	18
2	31
3	17
4	20
5	17
6	36
7	17
8	18

- Part A. What is the mean time, in seconds, of Bobbie's 100-meter hurdles?
 Part B. What is the median time, in seconds, of Bobbie's 100-meter hurdles?
 Part C. What is the mode time, in seconds, of Bobbie's 100-meter hurdles?
 Part D. If you were Bobbie, which of these results would you report to your friend?

Instructional Items

Instructional Item 1

There was a pie-eating contest at the county fair. The line plot below shows the number of pies each of the 10 contestants ate. Use the line plot to determine the mean, mode, median and range of the data.

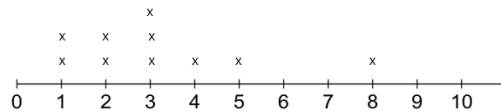

*The strategies, tasks and items included in the BIG-M are examples and should not be considered comprehensive.